

# Enphase Microinverter Model M215™

(M215-60-230)



## Corporate Headquarters Contact Information

Enphase Energy Inc.  
1420 N. McDowell Blvd.  
Petaluma, CA 94954  
USA  
Phone: +1 707-763-4784  
<http://www.enphase.com>  
[info@enphaseenergy.com](mailto:info@enphaseenergy.com)



## Other Information

For warranty text, refer to <http://www.enphase.com/warranty>.

Product information is subject to change without notice. All trademarks are recognised as the property of their respective owners.

Copyright © 2013 Enphase Energy. All rights reserved.

# Table of Contents

Important Safety Information .....	4
Read this First.....	4
Safety Instructions .....	4
The Enphase Microinverter System .....	5
How the Microinverter Works.....	6
System Monitoring .....	6
Optimal Reliability .....	6
Ease of Design.....	6
Enphase Microinverter Installation .....	7
Compatibility and Capacity .....	7
Electrical Compatibility.....	7
Capacity .....	7
Parts and Tools Required .....	8
Enphase Equipment .....	8
Other Items .....	8
Lightning Surge Suppression .....	8
Installation Procedure .....	9
Step 1 – Measure AC Voltage at the Electricity Network Connection .....	9
Step 2 – Install the AC Branch Circuit Junction Box .....	10
Step 3 – Position the Enphase Engage Cable .....	11
Step 4 – Attach the Microinverters to the Mounting Rail .....	12
Step 5 – Dress the Engage Cable .....	13
Step 6 – Connect the Microinverters .....	14
Step 7 – Terminate the Unused End of the Engage Cable .....	15
Step 8 – Connect the Engage Cable to AC Junction Box(es) .....	16
Step 9 – Complete the Installation Map.....	17
Use the Enphase Installation Map .....	17
Alternative: Create Your Own Map .....	17
Step 10 – Connect the PV Modules .....	17
Step 11 – Build the Virtual Array .....	18
Commissioning and Operation .....	19
Commission the System .....	19
Operating Instructions.....	19
Troubleshooting .....	20
Status LED Indications and Error Reporting.....	20
Startup LED Operation: .....	20
Post-Startup LED Indications:.....	20
Reported Faults: .....	20
Troubleshoot an Inoperable Microinverter .....	21
Disconnect a Microinverter from the PV Module .....	22
Install a Replacement Microinverter .....	23
Technical Data .....	24
Technical Considerations .....	24
Technical Specifications .....	25
Enphase Installation Map .....	27
Sample Wiring Diagram – M215, 230 Vac, Single-Phase.....	28
Sample Wiring Diagram – M215, Three-Phase.....	29

# Important Safety Information

## Read this First

This manual contains important instructions for use during installation and maintenance of the Enphase M215™ Microinverter.

To reduce the risk of electrical shock, and to ensure the safe installation and operation of the Enphase Microinverter, the following safety symbols appear throughout this document to indicate dangerous conditions and important safety instructions.



**WARNING!** This indicates a situation where failure to follow instructions may be a safety hazard or cause equipment malfunction. Use extreme caution and follow instructions carefully.



**NOTE:** This indicates information particularly important for optimal system operation. Follow instructions closely.

## Safety Instructions

- Do not use Enphase equipment in a manner not specified by the manufacturer. Doing so may cause death or injury to persons, or damage to equipment.
- Perform all electrical installations in accordance with all applicable local electrical standards.
- Be aware that only qualified personnel should install or replace Enphase Microinverters.
- Do not attempt to repair the Enphase Microinverter; it contains no user-serviceable parts. If it fails, contact Enphase customer service to obtain an RMA (return merchandise authorisation) number and start the replacement process. Tampering with or opening the Enphase Microinverter will void the warranty.
- If the AC cable on the microinverter is damaged or broken, do not install the unit. Discard the unit.
- Before installing or using the Enphase Microinverter, read all instructions and cautionary markings in the technical description and on the Enphase Microinverter System and the PV equipment.
- Obtain proper approval for the installation from the authorities having jurisdiction.
- Be aware that the body of the Enphase Microinverter is the heat sink. Under normal operating conditions, the temperature is 15°C above ambient, but under extreme conditions the microinverter can reach a temperature of 80°C. To reduce risk of burns, use caution when working with microinverters.
- Do NOT disconnect the PV module from the Enphase Microinverter without first removing AC power.
- Be aware that the M215 has field adjustable voltage and frequency trip points that you must set before the system can produce power. Only an authorised installer with the permission and following requirements of the local electrical authorities should make adjustments.

# The Enphase Microinverter System

The Enphase Microinverter System is the world's most technologically advanced inverter system for use in grid-connected applications. This manual details the safe installation and operation of the Enphase Microinverter.

The three key elements of an Enphase Microinverter System include the:

- Enphase M215 Microinverter
- Enphase Envoy™ Communications Gateway
- Enphase Enlighten™ web-based monitoring and analysis software

This integrated system maximises energy harvest, increases system reliability, and simplifies design, installation and management.



## 1 Enphase Microinverters

- are installed beneath each solar module
- maximize energy harvest
- send AC power over AC wiring to the AC mains
- also send performance data via the AC wiring

## 2 Envoy Communications Gateway

- plugs into an AC outlet
- collects information via the AC wiring
- transmits data through a standard broadband router to the Internet
- collects information and transmits it to Enlighten in 5-minute intervals

## 3 Enphase Enlighten Monitoring

- provides monitoring and analysis
- allows performance data to be viewed from any web browser

## How the Microinverter Works

The Enphase Microinverter maximises energy production from your photovoltaic (PV) array. Each Enphase Microinverter is individually connected to one PV module in your array. This configuration means that an individual Maximum Peak Power Point Tracker (MPPT) controls each PV module. This ensures that the maximum power available from each PV module is exported to the electricity network regardless of the performance of the other PV modules in the array. That is, although individual PV modules in the array may be affected by shading, soiling, orientation, or PV module mismatch, the Enphase Microinverter ensures top performance for its associated PV module. The result is maximum energy production from your PV system.

## System Monitoring

Once you install the Envoy Communications Gateway and provide an Ethernet connection to your broadband router or modem, the Enphase Microinverters automatically begin reporting to the Enphase Enlighten web server. The Enlighten software presents current and historical system performance trends, and it informs you of PV system status.

## Optimal Reliability

Microinverter systems are inherently more reliable than traditional inverters. The distributed nature of a microinverter system ensures that there is no single point of system failure in the PV system. Enphase Microinverters are designed to operate at full power at ambient temperatures as high as 65° C (150° F). The microinverter housing is designed for outdoor installation and complies with the IP67 regulation:

IP67 protective factor definition: Entirely protected against the effects of dust and immersion.

## Ease of Design

PV systems using Enphase Microinverters are very simple to design and install. You will not need string calculations, and you can install individual PV modules in any combination of PV module quantity, type, age and orientation. You won't need to install cumbersome traditional inverters. Each microinverter quickly mounts on the mounting rail, directly beneath each PV module. Low voltage DC wires connect from the PV module directly to the co-located microinverter, eliminating the risk of personnel exposure to dangerously high DC voltage.

# Enphase Microinverter Installation

Follow the instructions in this section to install Enphase M215™ Microinverters.



**WARNING:** Be aware that only qualified personnel should connect the Enphase Microinverter to the electricity network.



**WARNING:** Be aware that installation of this equipment includes risk of electric shock. Normally earthed conductors may be unearthed and energised when an earth fault is indicated.

## Compatibility and Capacity

The Enphase M215 Microinverters are electrically compatible with most 60-cell PV modules. For more information, see Technical Data on page 24 of this manual.



**WARNING:** The M215 may be paired only with a 60-cell PV module.

Refer to the Enphase website (<http://www.enphase.com/support>) for a list of **electrically** compatible PV modules and approved mounting rail systems. To ensure **mechanical** compatibility, be sure to order the correct connector type for both microinverter and PV module from your distributor.

### Electrical Compatibility

Model Number	Works with PV Module Type	PV Module Connector Type
M215-60-230-S22	60 cell	MC-4 Type 2 Locking

### Capacity

Maximum number of M215s per 20 amp AC Branch Circuit	
Service type	Max M215s per AC branch circuit
230V single-phase	17
400V three-phase	27

## Parts and Tools Required

In addition to the microinverters, PV modules, mounting rail, and associated hardware, you will need the following.

### Enphase Equipment

- Enphase Envoy™ Communications Gateway
- Engage Cable, as needed



**NOTE: Order the correct Engage Cable type.** Use 5G2.5 Engage Cable at sites with three-phase service, or use 3G2.5 Engage Cable at sites with single-phase service. Check the labelling on the drop connectors to verify the voltage type.

- Sealing caps, as needed (for any unused drops on the Engage Cable)
- Terminators, as needed (one needed at the end of each AC branch circuit)
- Enphase disconnect tool (number 2 and 3 Phillips screwdrivers can be substituted)

### Other Items

- AC Junction boxes
- Gland or strain relief fitting (one per AC junction box)
- Bonding (Earthing) conductor
- Torque wrench, sockets, spanners for mounting hardware
- Adjustable spanner or open-ended spanner (for terminators)
- Tool for PV module locking connectors
- Handheld mirror (to view indicator lights on the undersides of the microinverters)
- Laptop or other computer for Envoy set up

## Lightning Surge Suppression

Enphase Microinverters have integral surge protection, greater than most traditional inverters. However, if the surge has sufficient energy, the protection built into the microinverter can be exceeded, and the equipment can be damaged. For this reason, Enphase recommends that you protect your system with lightning and/or surge suppression devices. In addition to having some level of surge suppression, it is important to have insurance that protects against lightning and electrical surges. Install devices that adhere to local standards.

In the United Kingdom, lightning protection and resulting voltage surge must be protected in accordance with BS 7671. It is assumed that the PV modules are installed in accordance with related standards and that the microinverter is a part of a broader lightning protection system in accordance with BS 7617.



## Installation Procedure

Installing the Enphase Microinverter System involves several key steps. Each step listed below is detailed in the following pages.

- Step 1** – Measure AC Voltage at the Electricity network connection
- Step 2** – Install the AC Branch Circuit Junction Box
- Step 3** – Position the Enphase Engage Cable
- Step 4** – Attach the Microinverters to the Mounting Rail
- Step 5** – Dress the Enphase Engage Cable
- Step 6** – Connect the Microinverters
- Step 7** – Terminate the Unused End of the Engage Cable
- Step 8** – Connect the Engage Cable to AC Junction Box(es)
- Step 9** – Complete the Installation Map
- Step 10** – Connect the PV Modules
- Step 11** – Build the Virtual Array



**WARNING:** DO NOT connect Enphase Microinverters to the electricity network or energise the AC circuit(s) until you have completed all of the installation procedures as described in the following sections.



**NOTE:** Enphase Microinverters will not begin exporting power until the Envoy Communications Gateway is installed and has detected all of the microinverters at the site. In addition, the grid profile must be configured and the Envoy must have propagated these settings to the microinverters. For instructions on this procedure, refer to the *Envoy Installation and Operation Manual* at <http://www.enphase.com/support>.

### Step 1 – Measure AC Voltage at the Electricity Network Connection

Measure AC line voltage at the electricity network connection to confirm that it is within range. Acceptable ranges are shown in the following table.

Single-Phase Service		Three-Phase Service	
L1 to neutral	207 to 253 Vac	L1 to L2 to L3	360 to 440 Vac
		L1, L2, L3 to neutral	207 to 253 Vac



**NOTE:** Be sure the Engage Cable you are using matches the electricity network connection at the site. Use 5G2.5 Engage Cable at sites with three-phase service, or use 3G2.5 Engage Cable at sites with single-phase service. Check the labelling on the drop connectors to verify the voltage type.

## Step 2 – Install the AC Branch Circuit Junction Box



**DANGER:** Risk of Electrical Shock. Be aware that installation of this equipment includes risk of electric shock. Do not install the AC junction box without first removing AC power from the Enphase System.



**WARNING:** Only use electrical system components approved for wet locations.



**WARNING:** Do NOT exceed the maximum number of microinverters in an AC branch circuit as listed on page 7 of this manual. You must protect each microinverter AC branch circuit with a 20A maximum breaker.

- a. Size the AC cable/wire size to account for voltage drop. Select conductor diameter based on the distance from the beginning of the microinverter AC branch circuit to the breaker in the AC mains.

All components of system wiring must be considered, including internal voltage drop within the length of Engage Cable. Typically, three wire sections and several wire terminations must be quantified. There is also some resistance associated with each circuit breaker. As all of these resistances are in series, they add together. Since the same current is flowing through each resistance, the total voltage drop is total current times the total resistance. For a single-phase system, the total resistance is equal to two times the one-way resistance. For a three-phase system, each of the three line currents and resistances must be calculated.

Standard guidelines for voltage drop on feeder and AC branch circuit conductors might not be sufficient for microinverter AC branch circuits that contain the maximum allowable microinverters. This is due to high inherent voltage rise on the AC branch circuit.

For more information, refer to our Technical Brief, *Voltage Drop Considerations for M215*, at <http://www.enphase.com/support>.

- b. Install an appropriate junction box at a suitable location on the mounting system. You can centre feed the branch, or you can install the junction box at the end of a row of PV modules.
- c. Provide an AC connection from the AC junction box back to the electricity network connection using equipment and practices as required by local jurisdictions.

### Step 3 – Position the Enphase Engage Cable

The Engage Cable is a continuous length of 2.5 mm<sup>2</sup>, outdoor rated cable with integrated connectors for microinverters. These connectors are preinstalled along the Engage Cable at intervals to accommodate PV module widths. The microinverters plug directly into the connectors, and the Engage Cable is terminated into the junction box that feeds electricity back to the system AC disconnect.



**NOTE: Make sure you are using the correct cable type.** Use 5G2.5 Engage Cable at sites with three-phase service, or use 3G2.5 Engage Cable at sites with single-phase service. Check the labelling on the drop connectors to verify the voltage type.

- a. Lay the Engage Cable along the route it will travel, positioning the connectors so that they align with the PV modules.



**WARNING:** Plan the AC branches so that they do not exceed the maximum number of microinverters in an AC branch circuit as listed on page 7 of this manual. You must protect each microinverter AC branch circuit with a 20A maximum breaker.

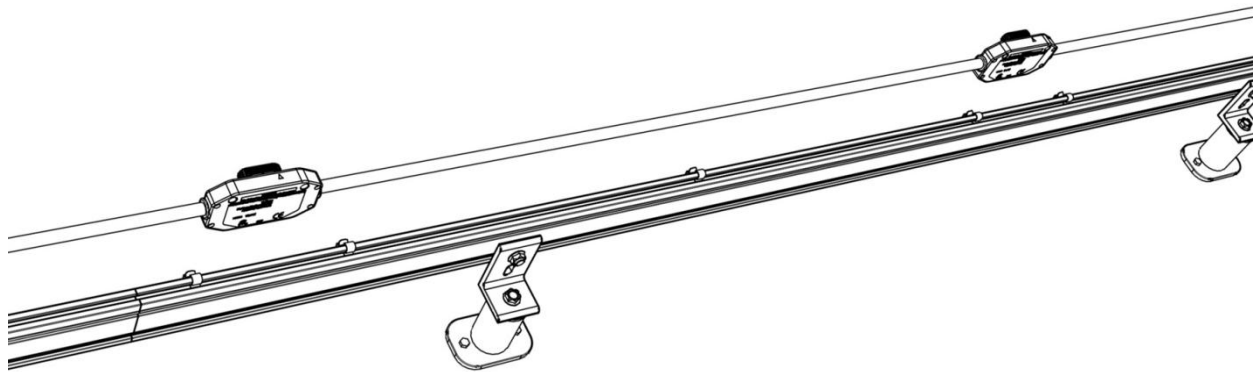

**NOTE:** Many PV modules have a central stiffening brace. In these cases, do **not** position the connector and microinverter at the exact centre of the PV module. Instead, position the drop connectors so that the connectors do not conflict with the braces.

- b. PV module widths vary by manufacturer. On the Engage Cable, connectors are spaced at intervals to allow for the widest PV modules compatible with Enphase Microinverters. If narrower PV modules are used, it may be necessary to account for excess cable by looping the cable at suitable intervals.

## Step 4 – Attach the Microinverters to the Mounting Rail

- a. Mark the approximate centres of each PV module on the mounting rail.
- b. Evaluate the location of the microinverter with respect to the PV module DC junction box or any other obstructions.
  - Ensure that the microinverter does not interfere with the PV module frame or stiffening braces.
  - Ensure that the connector from the microinverter can easily reach the connector on the Engage Cable.
- c. Allow a minimum of 1.9 cm (0.75 inches) between the roof and the bottom of the microinverter. Also allow 1.3 cm (0.50 inches) between the back of the PV module and the top of the microinverter.



**WARNING:** Do not mount the microinverter in a location that allows long-term exposure to direct sunlight (i.e., the microinverter should be covered by the PV module).

- d. With the **silver side of the microinverter facing up** and the black side facing down, mount one microinverter at each location using suitable hardware. The indicator light on the underside of the microinverter will be facing the roof.



**NOTE:** Installing the microinverter black side up is not recommended as it may allow moisture to collect between the cover and the body of the microinverter. If installing the M215 at an angle, check that this angle does not allow for collection of water in the recesses of the microinverter.

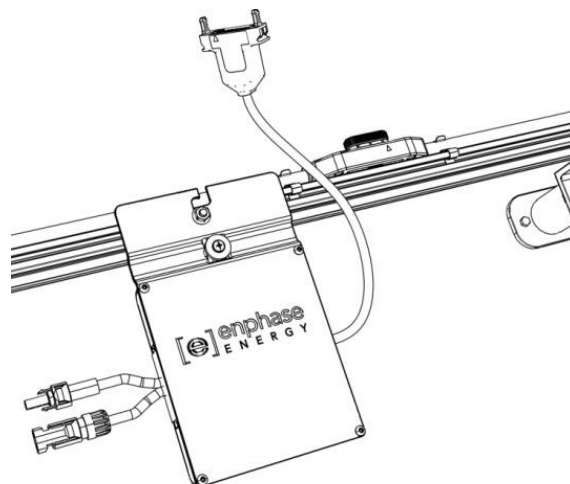

- e. Torque the microinverter fasteners to the values below.
  - 6 mm (1/4") mounting hardware – 5 N m (45 in-lbs)
  - 8 mm (5/16") mounting hardware – 9 N m (80 in-lbs)



**NOTE:** Using a power screwdriver to tighten the screws is not recommended due to the risk of thread galling.

- f. If you are using a bonding (earthing) electrode conductor to earth the microinverter chassis, attach the earthing electrode conductor to the microinverter earthing screw.
- g. Torque the 10/32 earthing cleat screw to 2 N m (20 in-lbs). Each Enphase Microinverter comes with an earthing clip that can accommodate a 10-16mm<sup>2</sup> conductor. You may also earth the mounting rail and PV module to this conductor using a crimp connection.



**NOTE:** The AC output neutral is not bonded to earth inside the microinverter.

## Step 5 – Dress the Engage Cable

- a. Attach the Engage Cable to the mounting rail using clips or tie wraps.

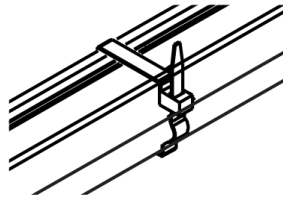

**NOTE:** There are two release-holes in the drop connector on the cable. These are **not** for mounting but are used to disconnect the connector. **Keep these release holes clear and accessible.**

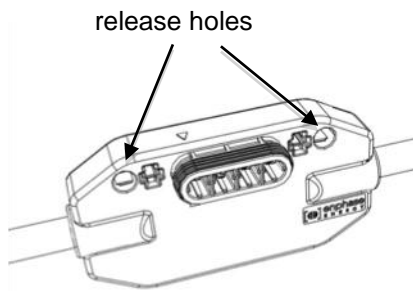

- b. Dress any excess in loops so that the Engage Cable does **not** contact the roof.

There are several ways to support the cable. One method is to place tie wraps or clips on either side of the connector. Use one or two additional clips, tie wraps, or other support scheme to secure the cable between connectors.

## Step 6 – Connect the Microinverters

- a. Remove and discard the temporary shipping cap from the Engage Cable and connect the microinverter. There are two latching mechanisms within the connectors. Listen for **two** clicks as the connectors engage. Ensure that **both** latching mechanisms have engaged.
- b. Repeat for all microinverters in the AC branch circuit.
- c. Cover any unused connector with a sealing cap. Listen for two clicks as the connectors engage. Ensure that **both** latching mechanisms have engaged.

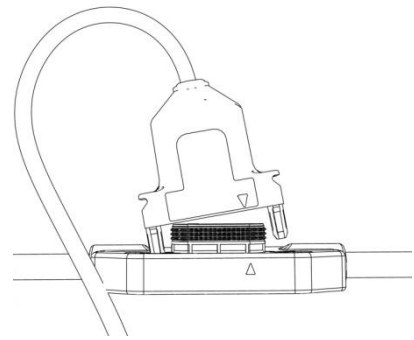

**NOTE:** Do not use the shipping cap to cover unused connectors. The shipping cap does not provide an adequate environmental seal. Enphase sealing caps are required for the system to be compliant to regulation and to protect against moisture ingress.

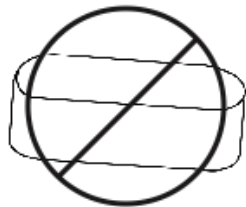
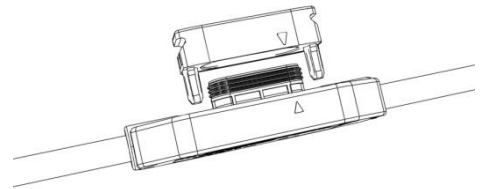

Enphase sealing caps are IP67 rated. Within the term “IP67”, “IP” indicates an Ingress Protection (IP) rating against dust and liquids. This specific rating of IP67 indicates that this connector protects against all dust particles and immersion in liquid.



**WARNING:** Make sure protective sealing caps have been installed on **all** unused AC connectors. Unused AC connectors are live when the system is energized by the electricity network. **Sealing caps may not be reused.**



**NOTE:** If you need to remove a sealing cap, you must use the Enphase disconnect tool or a #3 Phillips screwdriver. Sealing caps may not be reused.

## Step 7 – Terminate the Unused End of the Engage Cable

Terminate the far end of the Engage Cable as follows.

- a. Remove 60mm (2.5 inches) of the cable sheath from the conductors.

- b. Slide the hex nut onto the Engage Cable.

- c. Insert the Engage Cable all the way into the wire organiser (up to the stop).

- d. Bend the individual wires back into the recesses in the wire organiser so that they angle back toward the cable.

- e. Cut the individual wires so that no excess extends outside of the wire organiser. The portions that angle back will need to extend enough to fit neatly into the 0.5 cm (0.2 in) recesses in the wire organiser and flush with the edge of the cap.

- f. Screw the hex nut onto the cap. **Never unscrew the hex nut as this can twist and damage the cable.**

- g. Hold the cap with an Enphase disconnect tool, or insert a #2 Phillips screwdriver.

- h. Use a 22mm (7/8 inch) spanner to tighten the hex nut until the latching mechanism is screwed all the way to the base.

- i. Use a tie wrap or cable clip to attach the cable to the mounting rail, so that the Engage Cable and terminator do not touch the roof.

- j. Ensure that all cabling is located underneath the PV module.

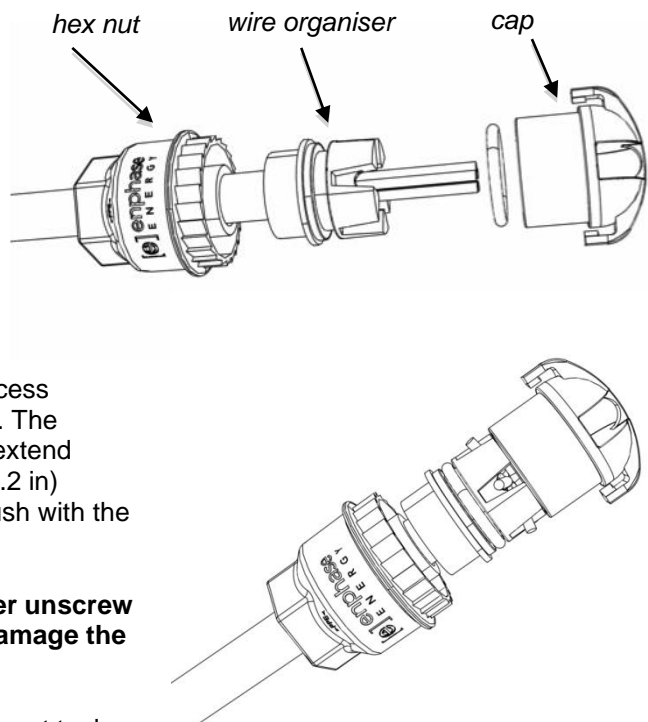

## Step 8 – Connect the Engage Cable to AC Junction Box(es)

- a. Connect Engage Cable into the AC branch circuit junction box using an appropriate gland or strain relief fitting. The Engage Cable requires a strain relief connector with an opening of 1.3 cm (0.5 inches) in diameter.
  - b. Connect the Engage Cable into additional AC junction boxes as needed to transition to conduit between smaller sub-arrays.
- Refer to the wiring diagrams located on page 28 for more information.

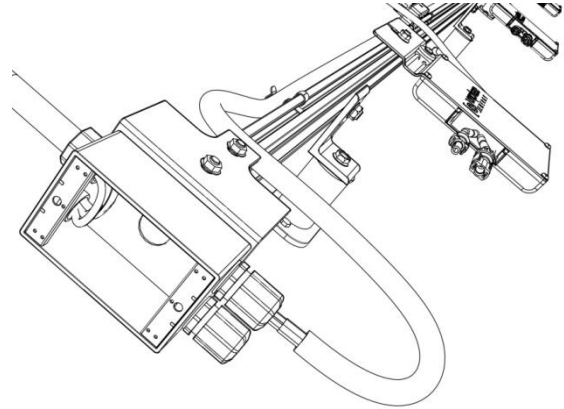

Single-phase 3G2.5	Three-phase 5G2.5
L1 - Brown	L1 - Brown
(not present)	L2 - Black
(not present)	L3 - Grey
Neutral - Blue	Neutral - Blue
Earth – Green / yellow (acts as equipment earth)	Earth – Green / yellow (acts as equipment earth)

Wires are identified as follows. For 400 Vac, L1 is sheathed in brown, L2 is sheathed in black, L3 is sheathed in grey, Neutral is sheathed in blue, and protective earth is sheathed in green/yellow. The earthing wire is used to earth the microinverters. For single-phase, L2 and L3 are not present.

Balanced 400 Vac (3-phase) is accomplished by alternating phases between microinverters as shown:

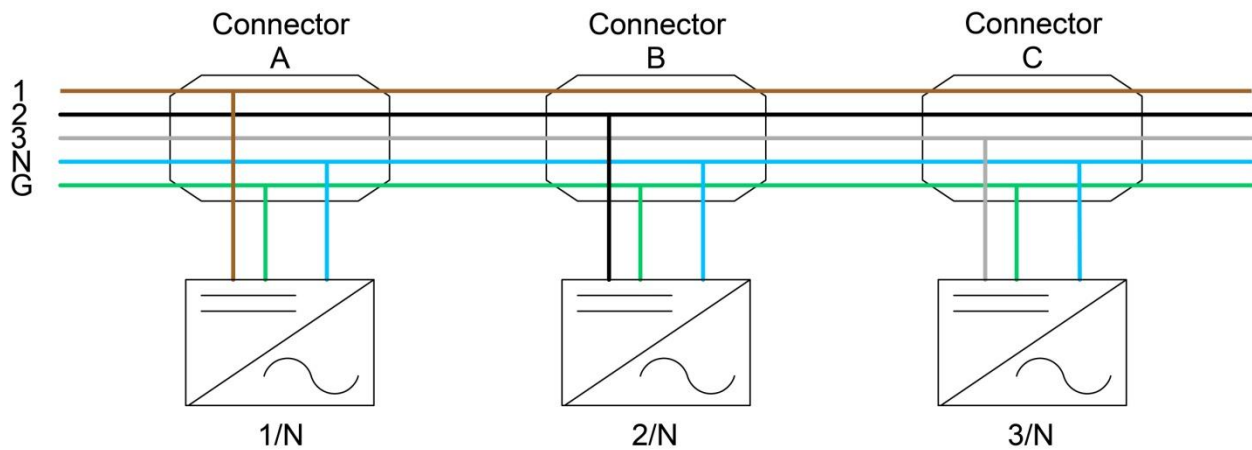

**WARNING:** Treat all connector contacts as though they are live. The 5G2.5 Engage Cable drop connector contains two live phases.



## Step 9 – Complete the Installation Map

The Enphase Installation Map is a diagrammatic representation of the physical location of each microinverter in your PV installation. The virtual array in Enlighten is created from the map you create. Use the blank map on page 27 to record microinverter placement for the system, or provide your own layout if a larger or more intricate installation map is required.

### Use the Enphase Installation Map

- Each Enphase Microinverter has a removable serial number label located on the mounting plate. Peel the removable serial number label from each Enphase Microinverter and affix it to the respective location on the Enphase installation map (see map on page 27). Remember to keep a copy of the installation map for your records.

### Alternative: Create Your Own Map

- Draw a top-down view of the array using the Array Map template (using either the grid on Side A or the freeform area on Side B). Make sure to leave enough room to place the serial number stickers.
- When installing the microinverters, remove the serial number labels located next to the DC input cables and place them in the correct order on your drawing of the system. Remember to keep a copy of the installation map for your records.

## Step 10 – Connect the PV Modules



**NOTE:** Completely install all microinverters and all system AC connections prior to installing the PV modules.

- Mount the PV modules above the microinverters.
- Mate the microinverters and PV modules as required. Repeat for all remaining PV modules using one microinverter for each PV module.



**WARNING:** The M215 can be paired only with a 60-cell PV module.

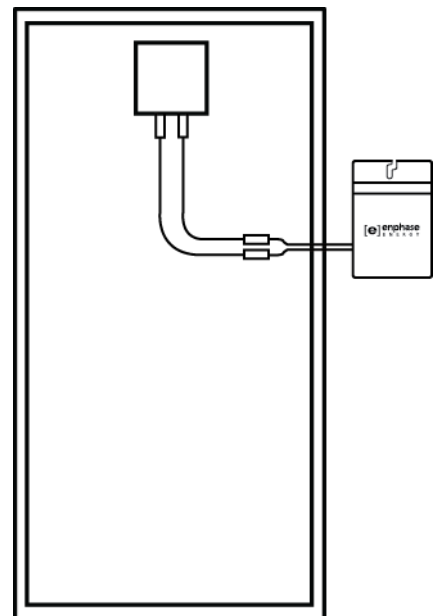

## Step 11 – Build the Virtual Array

When the system is energised and the Envoy detects all the installed microinverters, you can create the virtual array in Enlighten from the installation map you created. Once the virtual array is built, Enlighten displays a graphic representation of the PV system. It also shows detailed current and historical performance information. Go to <http://www.enphase.com> for more information on the Enphase Enlighten web-based monitoring and analysis.

- a. Scan the installation map and upload it to the Activation form online.
- b. Use Array Builder to create the virtual array in Enlighten. Use the installation map created in step 9 as your reference.



**NOTE:** Go to <http://enphase.com/support/videos/> to view the Array Builder demo.

- c. If you do not already have an account, go to <http://www.enphase.com> and click “Enlighten Login” to register.

## Commissioning and Operation



**WARNING:** Be aware that only qualified personnel must connect the Enphase Microinverter to the electricity network.



**WARNING:** Ensure that all AC and DC wiring is correct. Ensure that none of the AC and DC wires are pinched or damaged. Ensure that all AC junction boxes are properly closed.



**NOTE:** Obtain proper approval for the installation from the authorities having jurisdiction.



**NOTE:** The Status LED on the underside of each microinverter will blink green six times to indicate normal start-up operation approximately two minutes after DC power is applied.



**REMINDER:** Enphase Microinverters will not begin exporting power until the Envoy Communications Gateway is installed and has detected all of the microinverters at the site. In addition, the grid profile must be configured and the Envoy must have propagated these settings to the microinverters.

For instructions on installing the Envoy and configuring the grid profile, refer to the *Envoy Installation and Operation Manual* at <http://www.enphase.com/support>.

### Commission the System

To commission the Enphase Microinverter PV system:

1. Turn ON the AC disconnect or circuit breaker (such as an isolation switch) for each microinverter AC branch circuit.
2. Turn ON the main AC switch.
3. The Enphase Microinverters will begin communicating over the power lines to the Envoy. The time required for all microinverters to report to the Envoy will vary with the number of microinverters in the system. The first units should be detected within 15 minutes. After that, the Envoy will detect approximately four microinverters per minute.
4. You will need to configure the microinverters with the appropriate grid profile before they can produce power. For instructions on this procedure, refer to the *Envoy Installation and Operation Manual* at <http://www.enphase.com/support>.



**NOTE:** If the Envoy has not been set up with a grid profile for the microinverters, they will not produce energy. The microinverters must be configured with the appropriate grid profile as part of the commissioning process.

### Operating Instructions

The Enphase Microinverter is powered on when sufficient DC voltage from the PV module is applied. The Status LED of each microinverter will blink green six times to indicate normal start-up operation approximately two minutes after DC power is applied. You may need to use a handheld mirror to view indicator lights on the undersides of the microinverters.

## Troubleshooting

Adhere to all the safety measures described throughout this manual. Qualified personnel can use the following troubleshooting steps if the PV system does not operate correctly.



**WARNING:** Do not attempt to repair the Enphase Microinverter; it contains no user-serviceable parts. If it fails, contact Enphase customer service to obtain an RMA (return merchandise authorisation) number and start the replacement process.

### Status LED Indications and Error Reporting

#### Startup LED Operation:

The Status LED of each microinverter will blink green six times to indicate normal start-up operation approximately two minutes after DC power is applied.

Six short red blinks after DC power is first applied to the microinverter indicate a failure during microinverter startup.

#### Post-Startup LED Indications:

Use a handheld mirror to view indicator lights on the undersides of the microinverters. LED states are:

- **Flashing Green:** AC grid valid and communicating with Envoy
- **Flashing Orange:** AC grid valid but not able to communicate with Envoy
- **Flashing Red:** Not producing power. AC grid invalid (Voltage or Frequency). This may happen when the microinverters have not yet been configured with a Grid Profile.
- **Solid Red plus flashing Green:** DC input earth resistance fault active, AC grid valid and communicating with Envoy
- **Solid Red plus flashing Orange:** DC input earth resistance fault active, AC grid valid but not able to communicate with Envoy
- **Solid Red:** DC input earth resistance fault active and the AC grid is invalid. This may happen when the microinverters have not yet been configured with a Grid Profile.

#### Reported Faults:

All faults are reported to the Envoy. Refer to the *Envoy Installation and Operation Manual* for troubleshooting procedures.

## Troubleshoot an Inoperable Microinverter

To troubleshoot an inoperable microinverter, follow the steps in the order shown.



**WARNING:** Be aware that only qualified personnel should troubleshoot the PV array or the Enphase Microinverter.



**WARNING:** Never disconnect the DC wire connectors under load. Ensure that no current is flowing in the DC wires prior to disconnecting.



**WARNING:** Always disconnect AC power before disconnecting the PV module wires from the Enphase Microinverter. The AC connector of the microinverter is suitable as a disconnecting means.



**WARNING:** The Enphase Microinverters are powered by DC power from the PV modules. Make sure you disconnect the DC connections and reconnect DC power to watch for the six short LED blinks two minutes after DC is applied.

1. Check the connection to the electricity network and verify the utility voltage and frequency are within allowable ranges.
2. Verify that AC line voltage at the electrical distribution board or consumer unit and at the AC junction box for each AC branch circuit are within the ranges are shown in the following table:

Single-phase service		Three-phase service	
L1 to neutral	207 to 253 Vac	L1 to L2 to L3	360 to 440 Vac
		L1, L2, L3 to neutral	207 to 253 Vac

3. Verify that power from the electricity network is present at the microinverter in question by removing AC, then DC power. **Never disconnect the DC wires while the microinverter is producing power.**
4. Re-connect the DC PV module connectors. The Status LED of each microinverter will blink green six times to indicate normal start-up operation two minutes after DC power is applied.
5. Check the AC branch circuit between all the microinverters. As described in the previous step, verify that all microinverters are energised by the electricity network.
6. Make sure that any upstream AC disconnects (or isolators), as well as the dedicated circuit breakers for each AC branch circuit, are functioning properly and are closed.
7. Verify the PV module DC voltage is within the allowable range shown in the Technical Data section on page 24 of this manual.
8. Check the DC connections between the microinverter and the PV module.
9. If the problem persists, contact Customer Support at [support@enphase.com](mailto:support@enphase.com).



**WARNING:** Do not attempt to repair the Enphase Microinverter; it contains no user-serviceable parts. If it fails, contact Enphase customer service to obtain an RMA (return merchandise authorisation) number and start the replacement process.

## Disconnect a Microinverter from the PV Module

To ensure the microinverter is not disconnected from the PV modules under load, adhere to the following disconnection steps in the order shown:

1. De-energize the AC branch circuit breaker.
2. Disconnect the microinverter from the Engage Cable as follows:

The Enphase AC connectors are tool-removable only. To disconnect a microinverter from the Engage Cable, insert the two large prongs of the disconnect tool (shown below) into the two holes in the drop connector. Rock the connector back and forth while pulling gently to disengage.

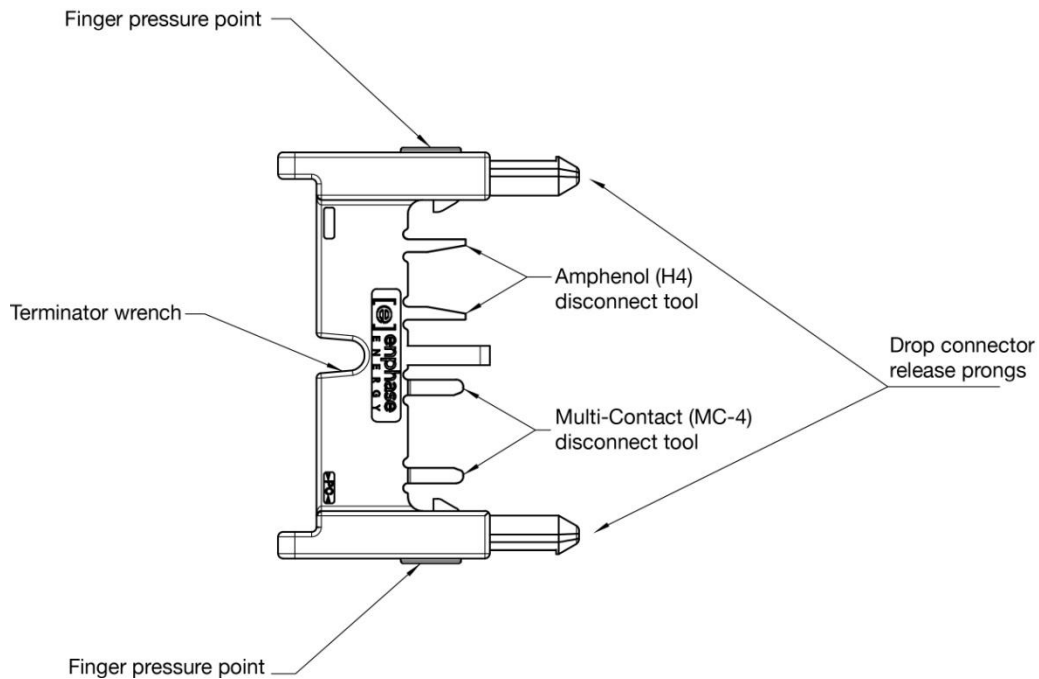

If the disconnect tool is not available, insert a #3 Phillips screwdriver into one hole, and rock that side of the drop connector out. Then, insert the screwdriver into the other hole and pull the connector out entirely.

3. Using a clamp on meter, verify there is no current flowing in the DC wires between the PV module and the microinverter.
4. Take care when measuring DC current, as most clamp-on meters must be zeroed first and tend to drift with time.
5. Disconnect the PV module DC wire connectors from the microinverter using the Enphase disconnect tool.
6. Loosen the ground cleat screw and remove the grounding electrode conductor.
7. Remove the microinverter from the mounting rail.



**WARNING:** Do not leave AC connectors on the Engage Cable uncovered for an extended period. If you do not plan to replace the microinverter immediately, you must cover any unused connector with a sealing cap. **Sealing caps may not be reused.**

## Install a Replacement Microinverter

1. Verify that the AC branch circuit breaker is de-energised.
2. With the silver side of the microinverter facing up and the black side facing down, attach the replacement microinverter to the mounting rail using hardware recommended by your mounting rail vendor.
3. Torque the microinverter fasteners to the values below.
  - 6 mm (1/4") mounting hardware – 5 N m (45 in-lbs)
  - 8 mm (5/16") mounting hardware – 9 N m (80 in-lbs)



**NOTE:** Using a power screwdriver to tighten the fasteners is not recommended due to the risk of thread galling.

4. If you are using a bonding (earthing) electrode conductor to earth the microinverter chassis, attach the earthing electrode conductor to the microinverter earthing screw. Torque the 10/32 earthing cleat screw to 2 N m (20 in-lbs).



**NOTE:** Using a power screwdriver to tighten the earthing clamp screw is not recommended due to the risk of thread galling.

5. Attach the bonding (earthing) electrode conductor, if used, to the microinverter earth clamp.
6. Connect the microinverter. There are two latching mechanisms within the connectors. Listen for two clicks as the connectors engage. Ensure that **both** latching mechanisms have engaged.
7. Mount the PV module above the microinverter.
8. Mate the microinverter and PV module as required.
9. Energize the AC branch circuit breaker, and verify operation of the replacement microinverter by checking the indicator light on the underside of the microinverter. You may need a handheld mirror to see the indicator light.
10. Initiate a device scan at the Envoy. To do this, press and hold the Menu button on the Envoy for two seconds to bring up the Envoy menu on the LCD window. When the LCD window displays "Enable Device Scan", release the Menu button.

This starts a 30-minute scan at the Envoy to discover the new microinverter.
11. Use Enlighten's Array Builder function to add the newly detected microinverter to the virtual array.
12. Ship the old microinverter to Enphase using the supplied return shipping label.

## Technical Data

### Technical Considerations

The Enphase M215 Microinverters are electrically compatible with most 60-cell PV modules. Be sure to verify the voltage and current specifications of your PV module match those of the microinverter. For more information, refer to our list of compatible PV modules at <http://www.enphase.com/support>.



**WARNING:** You must match the DC operating voltage range of the PV module with the allowable input voltage range of the Enphase Microinverter.



**WARNING:** The maximum open circuit voltage of the PV module must not exceed the specified maximum input voltage of the Enphase Microinverter.

The output voltage and current of the PV module depends on the quantity, size and temperature of the PV cells, as well as the insolation on each cell. The highest PV module output voltage occurs when the temperature of the cells is the lowest and the PV module is at open circuit (not operating). The maximum short circuit current rating of the PV module must be equal to or less than the maximum input DC short circuit current rating of the microinverter.





## Technical Specifications

Enphase M215 Microinverter Parameters				
Topic	Unit	Min	Typical	Max
<b>DC Parameters</b>				
Recommended maximum input power	W			260
MPPT voltage range	V	22	29	36
Operating range	V	16		36
Maximum DC input voltage	V			45
Minimum / Maximum start voltage	V	22		45
Maximum DC input short circuit current	A			15
Maximum DC input current	A			10.5
<b>AC Parameters</b>				
Maximum AC output Power (-40 to 65 °C)	W		215	
Output power factor		0.95	0.99	1
Nominal AC output voltage			230	
Maximum AC output current, 230 Vac	A		.93	
Number of AC phases			1	
<b>Operational Data</b>				
Maximum microinverters per 20 amp AC branch circuit				
230 Vac		1		17
400 Vac (three-phase)		1		27
Total Harmonic Distortion	%		3.0	5
Ambient temperature range	°C	-40		65
Operating temperature range (internal)	°C	-40		85
Storage temperature range	°C	-40		65
<b>Efficiency</b>				
EN50530 weighted efficiency (EU)	%		95.4	
Static MPPT efficiency (weighted, EN 50530)	%		99.6	
Dynamic MPPT efficiency (weighted, EN 50530) slow irradiation changes	%		99.3	
Dynamic MPPT efficiency (weighted, EN 50530) fast irradiation changes	%		99.3	
Dynamic MPPT efficiency (weighted, EN 50530) start up and shut down	%		99.8	
Night Tare Loss	mW		50	

Enphase M215 Microinverter Parameters				
Topic	Unit	Min	Typical	Max
<b>Features and Compliance</b>				
Dimensions, not including mounting bracket (approximate)	17.3 cm x 16.4 cm x 2.5 cm (6.8" x 6.45" x 1.0")			
Weight	1.6 Kg (3.5 Lbs)			
Enclosure environmental rating	IP67			
Cooling	Convective – no fan			
Communication	Power line			
ADD pollution rating	2			
Grid Compliance	<ul style="list-style-type: none"> <li>• France VDE0126</li> <li>• Belgium C10_11</li> <li>• Italy CEI_0-21</li> <li>• Luxembourg VDE0126</li> <li>• Luxembourg C10_11</li> <li>• Netherlands EN50438</li> <li>• United Kingdom G83/1-1, G59/2</li> <li>• Australia AS4777</li> </ul>			
Other Compliance	<ul style="list-style-type: none"> <li>• Directive 2006/95/EC,</li> <li>• Directive 2004/108/EC,</li> <li>• EN 50065-1:2001</li> <li>• EN 50065-2-1:2003</li> <li>• EN 50065-2-2:2003</li> <li>• EN 50065-2-3:2003</li> <li>• EN 61000-3-2:2006</li> <li>• EN 61000-3-3:1995</li> <li>• EN 61000-6-1:2007</li> <li>• EN 61000-6-2:2005</li> <li>• EN 61000-6-3:2007</li> <li>• EN 61000-6-4:2007</li> <li>• EN 62109-1:</li> <li>• EN 62109-2: 2009</li> <li>• VDE-0126-1-1</li> <li>• DK5940</li> <li>• C10/11</li> </ul>			
Integrated AC disconnect	The AC connector has been evaluated and approved for use as the required load-break disconnect.			
Protective class	1			

# Enphase Installation Map

Panel Group: Azimuth: Tilt: sheet <u>    </u> of <u>    </u>	Customer information:  	Installer information:  	N S E W (circle one) 			
1	2	3	4	5	6	7
A						
B						
C						
D						
E						
F						
G						
H						
J						
K						
L						
M						
Scan completed map and upload it to Enphase. Click "Add New Activation" at <a href="http://www.enlighten.enphaseenergy.com">www.enlighten.enphaseenergy.com</a> . Use this map to build the virtual array in Enlighten's Array Builder.						
Envoy Serial Label					INSTALLATION MAP	
DOCUMENT NUMBER 140-00003 REVISION: 04						

### Sample Wiring Diagram – M215, 230 Vac, Single-Phase

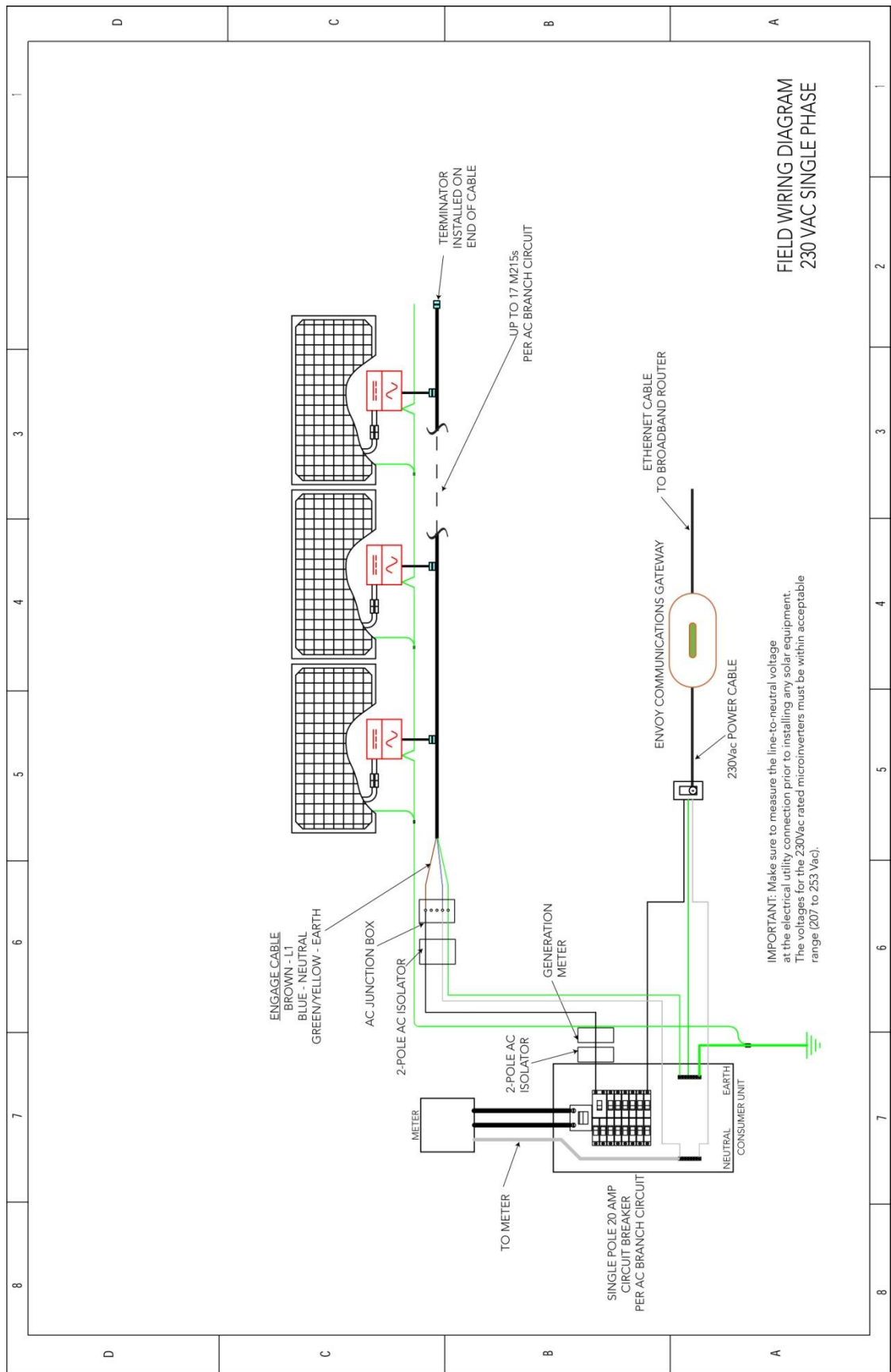

# Sample Wiring Diagram – M215, Three-Phase

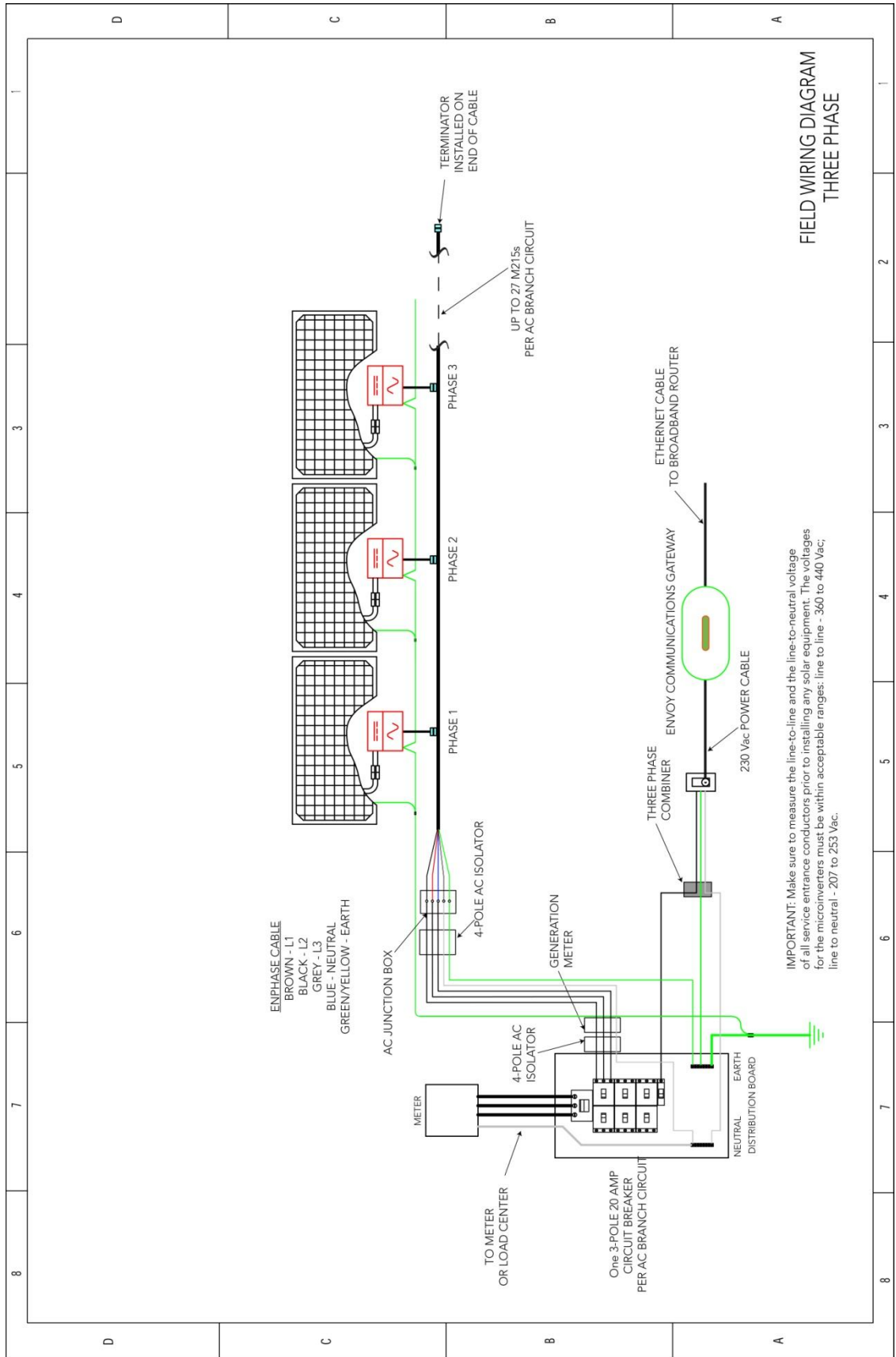

**Corporate Headquarters Contact Information**

Enphase Energy Inc.  
1420 N. McDowell Blvd.  
Petaluma, CA 94954  
USA  
Phone: +1 707-763-4784  
<http://www.enphase.com>  
[info@enphaseenergy.com](mailto:info@enphaseenergy.com)