

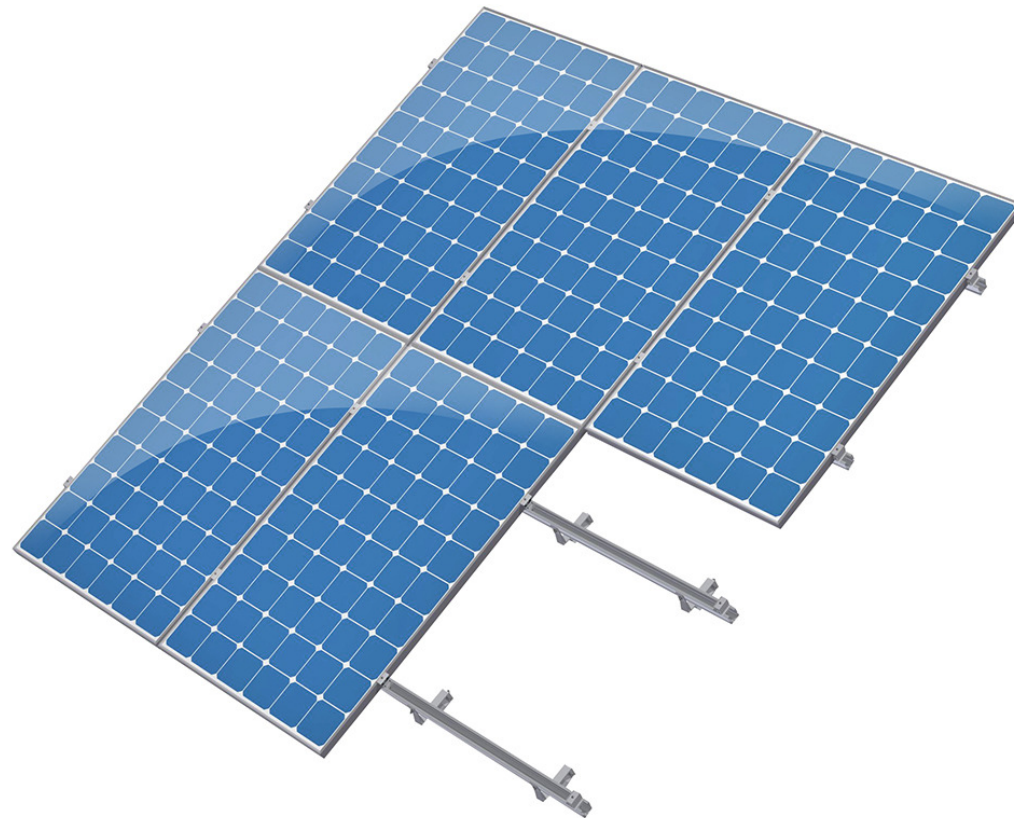

# Van der Valk Solar Systems

TRACKING AND FIXED SOLAR MOUNTING SYSTEMS

## Installation manual ValkPitched - Clamp



Congratulations on buying a Van der Valk Solar Systems mounting system and on helping the environment by deciding to install solar panels.

This document must be seen in addition to the installation manual and installation instructions.

- \* The general user instructions describe general installation and safety instructions.
- \* The installation manual shows you how to install the solar mounting system.
- \* The installation instruction gives you specific measures of the engineered mounting system as a result of the 1-2-3 PV Planner.

The instructions provided in these user instructions must be observed at all times. Read these instructions carefully and keep them in a safe place for future reference. Also follow the instructions stated in the manuals and instructions for the other system components that are a part of the overall PV system. All current structural, safety and building regulations must be observed.

Van der Valk Solar Systems B.V. will never be liable for any direct and/or indirect intangible or consequential loss ensuing from or connected to the failure to observe the instructions provided in these user instructions.

### Safety instructions for roofs

Solar mounting systems installed on roofs will be exposed to wind and snow.

The building in question will be subject to a greater load as a result of the PV system. A design calculation must be used to establish whether or not the building in question will be able to withstand the extra load. Where necessary, modifications need to be made.

### The standards applied (if applicable for specific solar mounting system)

EN 1990	Basis of structural design
EN 1991-1-3	Actions on structures / Snow loads
EN 1991-1-4	Actions on structures / Wind actions
EN 1993-1-1	Design of steel structures / General rules for buildings
EN 1993-1-3	Design of steel structures / Supplementary rules for cold formed members
EN 1997	Geotechnical design
EN 1998-1	Design of structures / General rules, seismic actions and rules for buildings
EN 1999-1-1	Design of aluminium structures
NEN 7250	Solar systems - Integration in roofs and facades - Building aspects (pending)
BS EN 1991-1-4	British Standard

### Application

To calculate the needed strength, ballast and foundation of the solar mounting system, according the Eurocodes, the specific location details have to be determined, e.g. wind zone, snow zone and height of the building. These need to be entered in the 1-2-3 PV Planner.

Foundations and strength of field systems are calculated with SolarTop.

### Type of solar panel

The Van der Valk Solar Systems mounting systems are universal mounting systems for solar panels. Almost any solar panel with or without an aluminium frame, possibly with mounting holes, can be mounted.

### Types of roof

Type of roof covering: bitumen, EPDM, PVC, concrete and other roof coverings. For ballast calculations the exact roof covering must be known. Before installing the solar mounting system, make sure that you carefully sweep the roof area.

The ballast calculation for flat roofs only applies for roofs with a slight pitch of up to 5°. Above this roof pitch, the system needs to be attached to the roof securely.

### Ballast

Flat roof systems can be attached to the roof or need to be supported by ballast, to make sure that the system is unable to move, lift or tip over.

The components supplied do not fully include the ballast required, which will be a number of tiles with a certain measurement and weight.

The number of tiles required per position, per type of solar panel, per roof area and per building height is calculated via the 1-2-3 PV Planner and can be seen in the installation instructions and foundation advise. The number of tiles specified per position will be vital to ensure that the mounting system can be used safely.

### Position

Restrictions also apply for the position of the system on a roof. The solar panels must be installed at a certain distance from the edge of the roof. Follow the scheme in the installation manual calculated by the 1-2-3 PV Planner.

### Guarantee

The guarantee provided is subject to the guarantee conditions stated in the general terms and conditions stipulated by Van der Valk Solar Systems BV. Our terms and conditions can be found on our website: [www.valksolarsystems.nl](http://www.valksolarsystems.nl).

The ValkBox® 3 mounting system is a product that has been produced by: Van der Valk Solar Systems B.V.,  
Registered with the chamber of commerce for Haaglanden  
under number 27355116. Internet: [www.valksolarsystems.nl](http://www.valksolarsystems.nl)

Issue date : March 2014  
Version: General user instructions v1 EN



# Van der Valk Solar Systems

## TRACKING AND FIXED SOLAR MOUNTING SYSTEMS

### Please Note

- This manual is not project specific.
- This manual is not legally binding.
- No right may be derived from this installation manual.
- Use this manual in combination with the 1-2-3 PV Planner.
- Check Datasheet Cable management for cable suggestions.

### Table of contents

General user instructions	Page	-
Mounting Smartline roof hooks	Page	01
Mounting the Slimline roof hooks	Page	02
Mounting the Strongline roof hooks	Page	03
Mounting the Hanger bolts roof hooks	Page	04
Mounting the Side+ profile (roof hook)	Page	05A
Mounting the Side+ profile (hanger bolt)	Page	05B
Coupling Side+ profile	Page	06
Mounting optional products	Page	07
Mounting Solar panels (side)	Page	08
Mounting Solar panels (middle)	Page	09
Mounting the cable clamps	Page	10



### Mounting the Smartline roof hooks

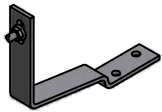

74.78.31 (horizontal profile)  
74.78.32 (vertical profile)

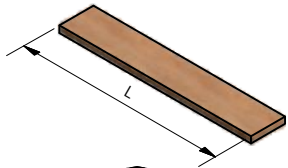

75.40. (L [mm])



77.38.40

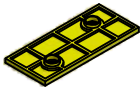

73.90.03

Optional:

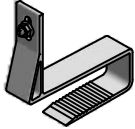

See page 2

Optional:

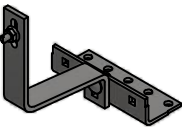

See page 3

Optional:



See page 4

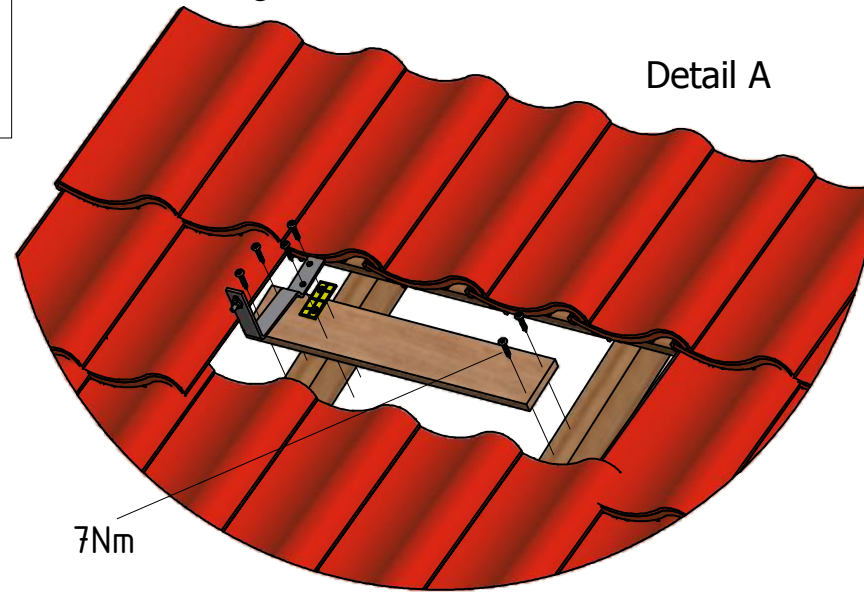

7Nm

Detail A

Detail A

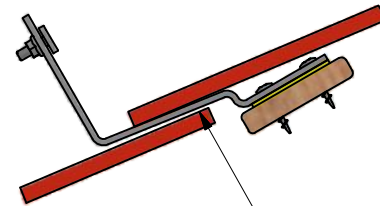

Keep at least 3 mm clearance

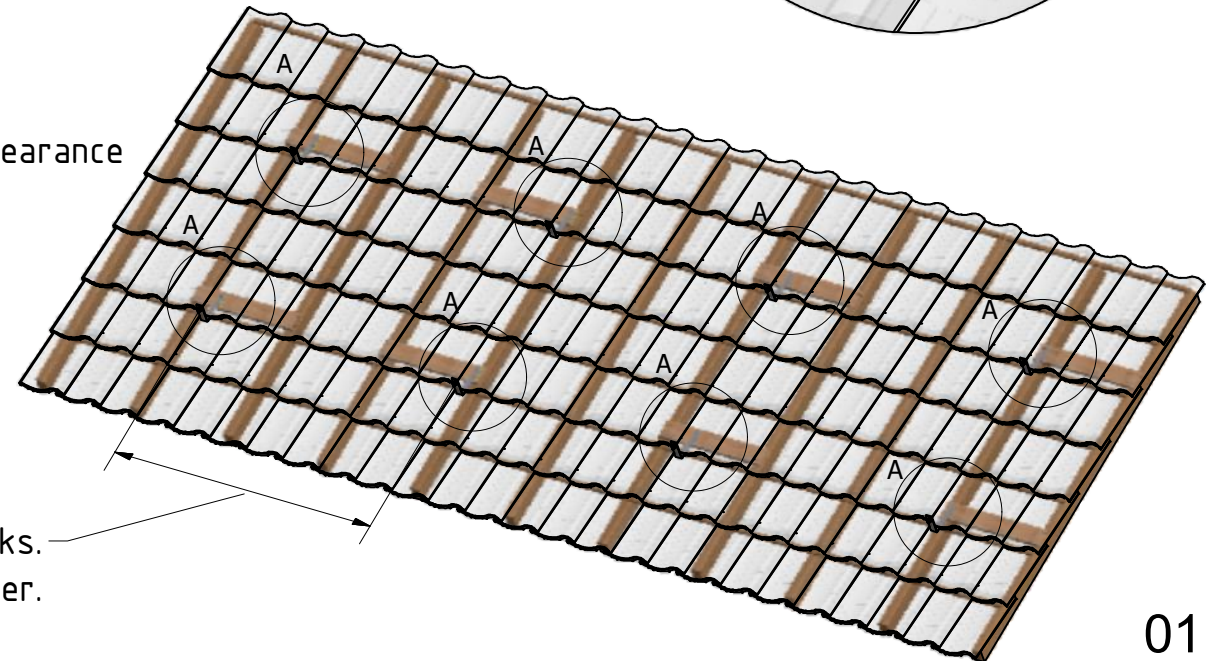

Distance between Roofhooks.  
See Installation instructions of the 1-2-3 PV Planner.



### Mounting the Slimline roof hooks



Fixed  
72.95.30 (horizontal profile)  
72.95.31 (vertical profile)

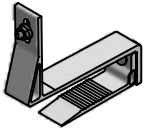

Adjustable  
72.95.40 (horizontal profile)  
72.95.41 (vertical profile)

Optional:

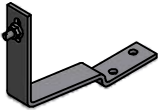

See page 1

Optional:

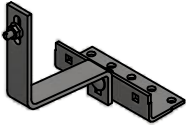

See page 3

Optional:



See page 4

Detail A

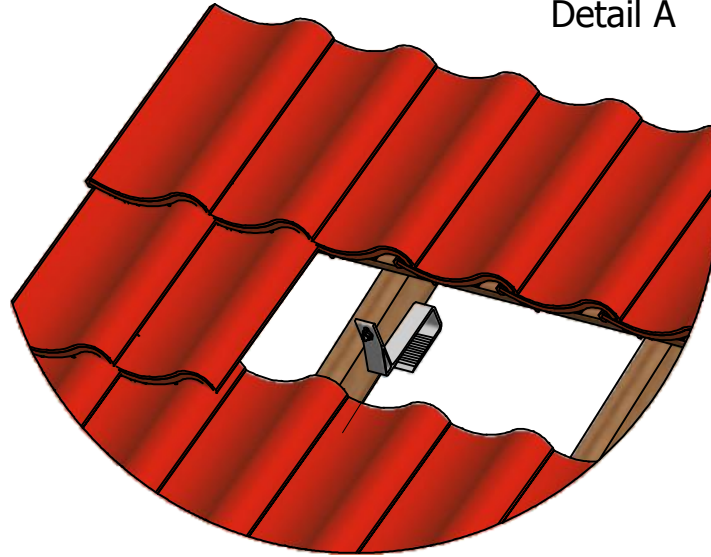

Detail A

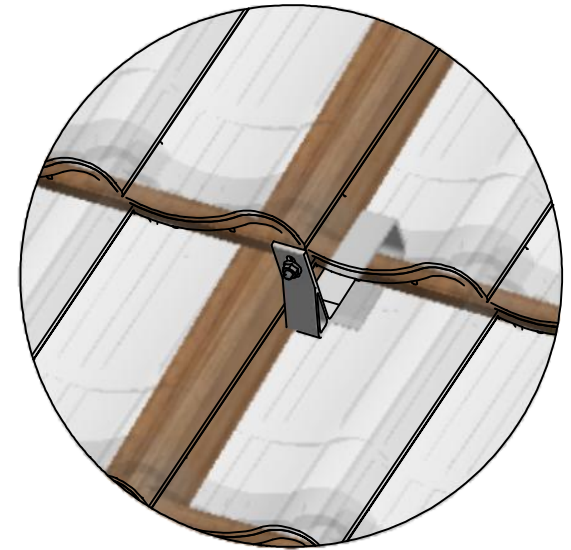

Check strenght of battens.

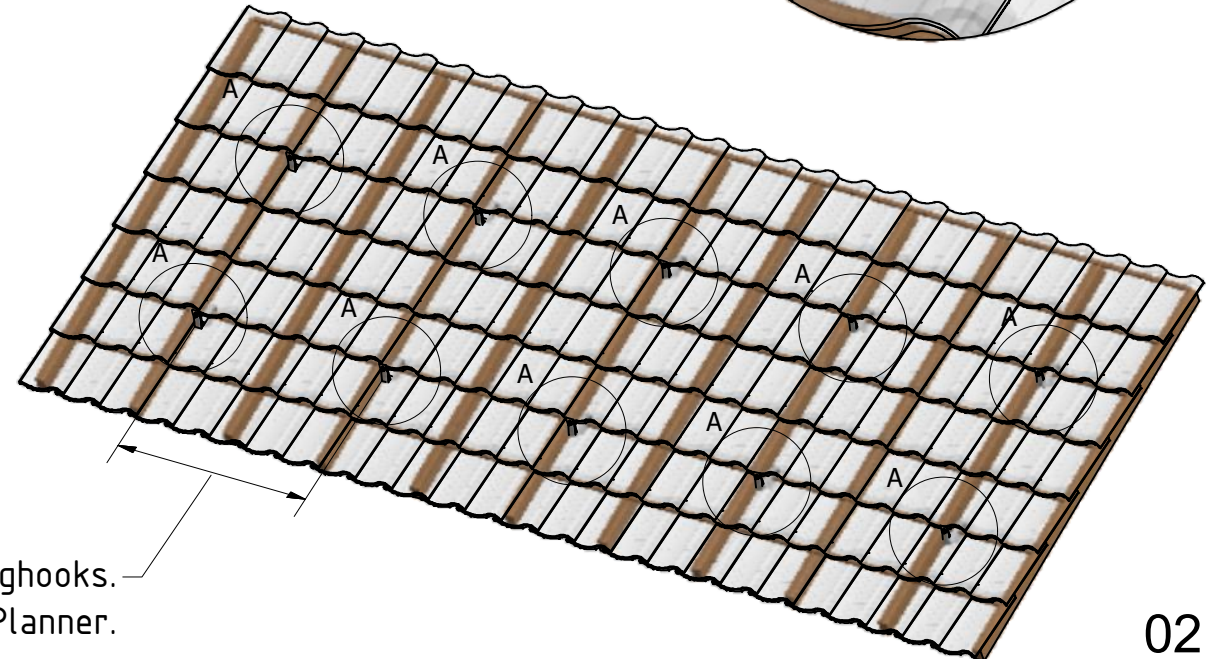
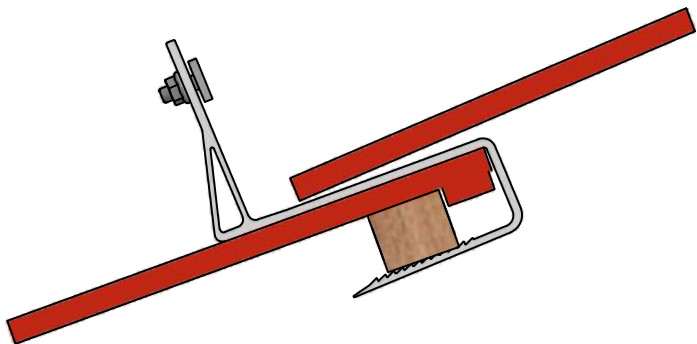

Distance between Hanghooks.

See Installation instructions of the 1-2-3 PV Planner.



### Mounting of the Strongline roof hooks

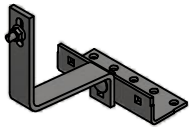

74.78.44 (horizontal profile)  
74.78.45 (vertical profile)



77.33.60

Optional:

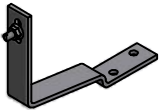

See page 1

Optional:



See page 2

Optional:



See page 4

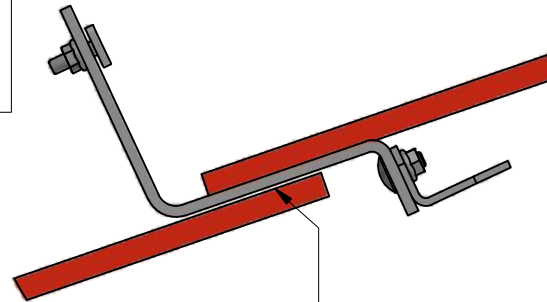

Clearance: > 0mm

Detail: B

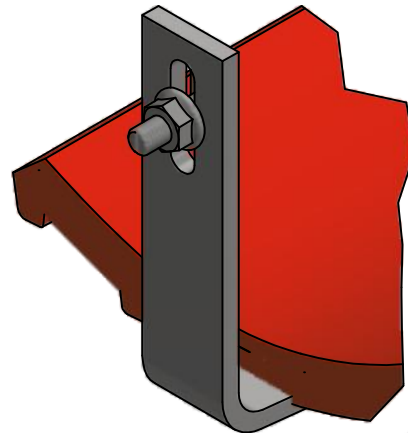

Detail: A

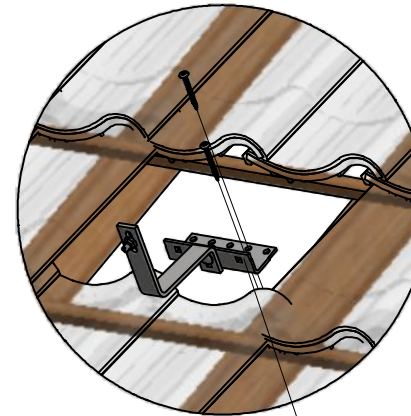

7Nm

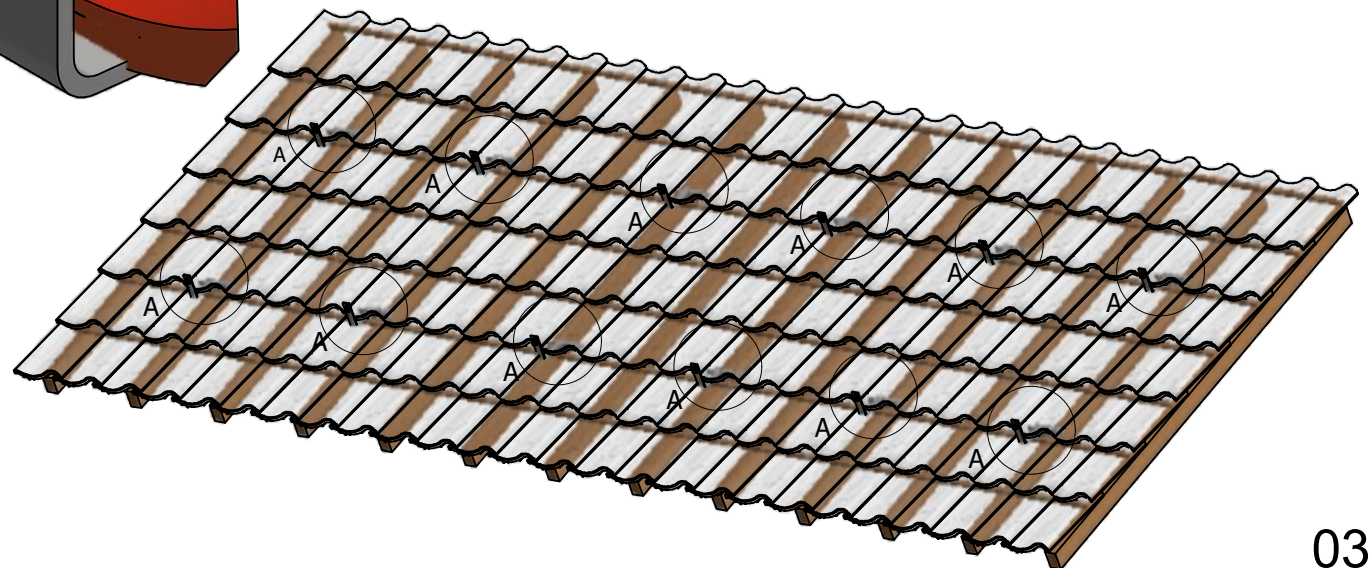
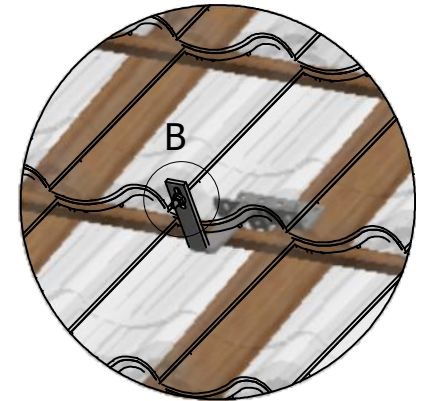



### Mounting the Hanger bolts

Detail A

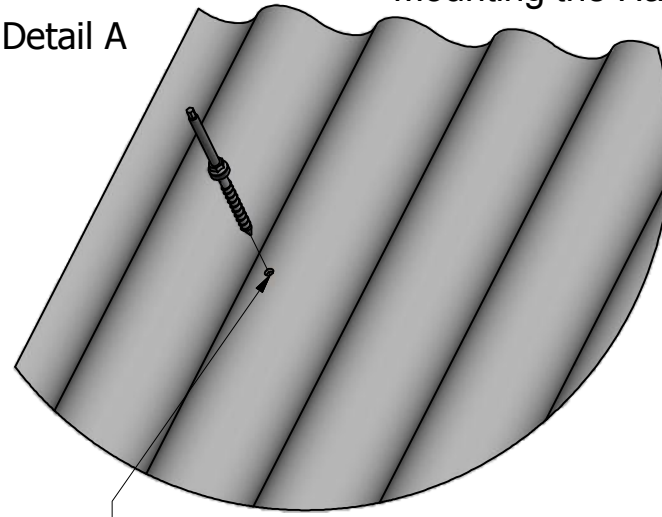

Detail A

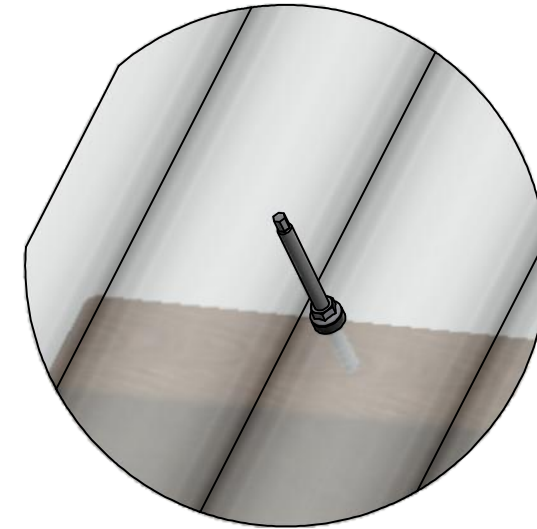

74.79.15 (M10x200)  
74.79.17 (M10x250)



74.79.20 (M12x250)  
74.79.22 (M12x350)

Optional:

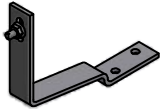

See page 1

Optional:



See page 2

Optional:

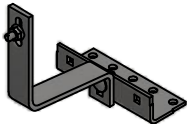

See page 3

Drill hole for Hangerbolts.  
M10 : Hole size 10 mm in corrugated sheet  
M12 : Hole size 12 mm in corrugated sheet

Pre drill in wood.  
M10 : Hole size 7.0 mm  
M12 : Hole size 8.4 mm

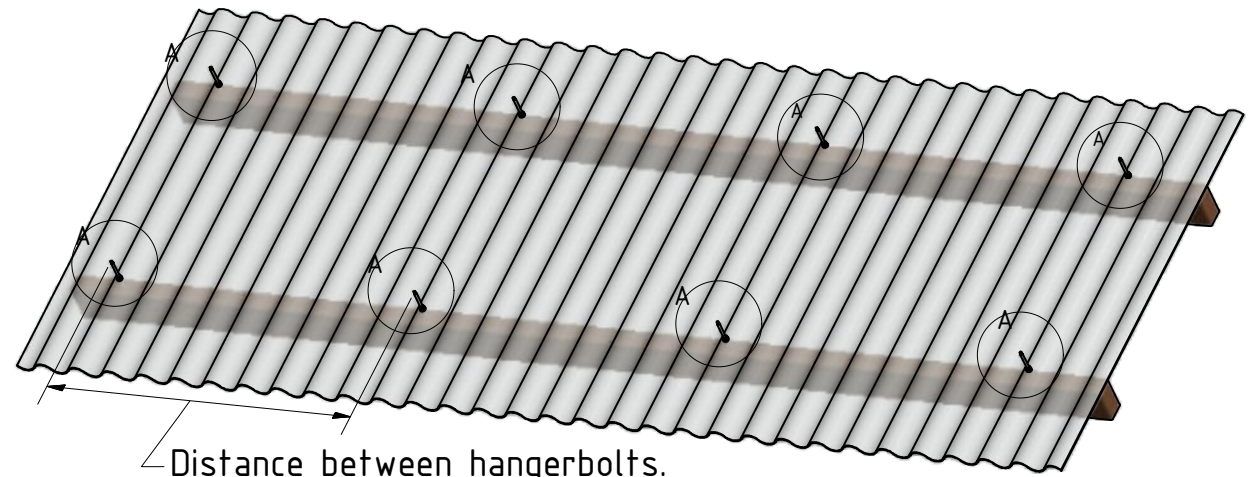

Distance between hangerbolts.

See Installation instructions of the 1-2-3 PV Planner.



### Mounting the Side+ profile

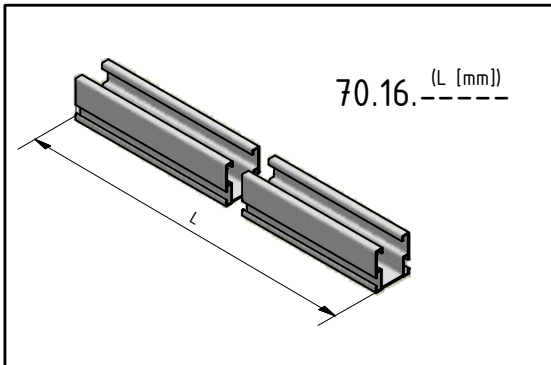

Detail A

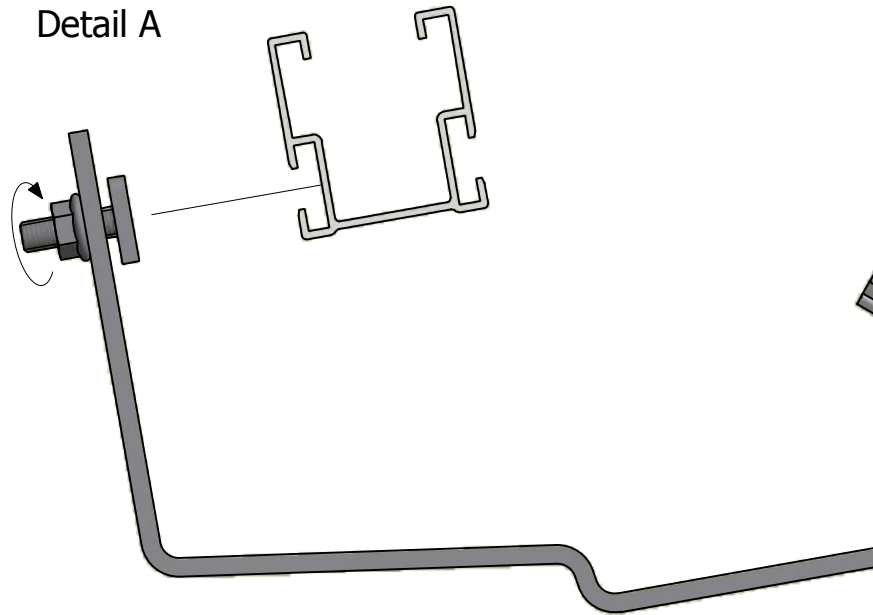

Detail B

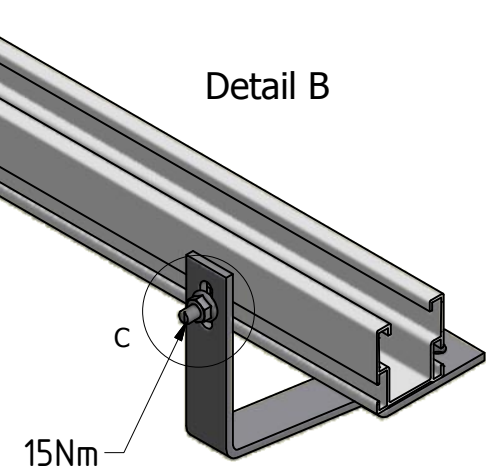

The groove of the bolt corresponds with the orientation of the bolt head.

Detail C

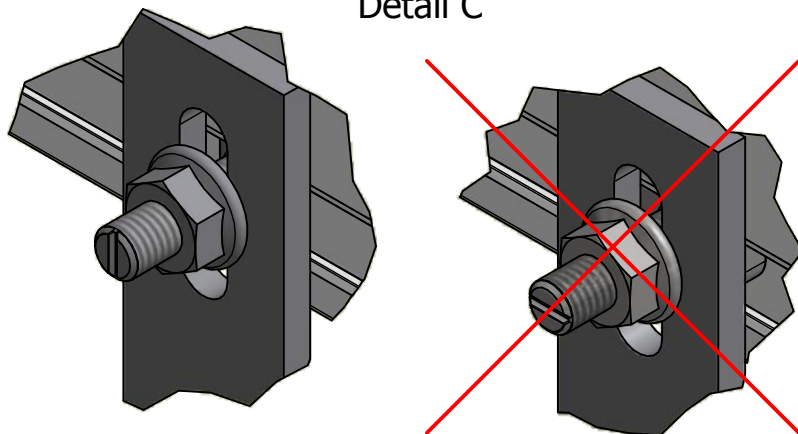



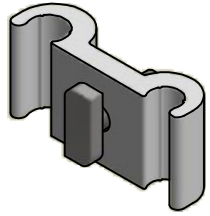

72.11.00

The groove of the bolt corresponds with the orientation of the bolt head.

Detail C

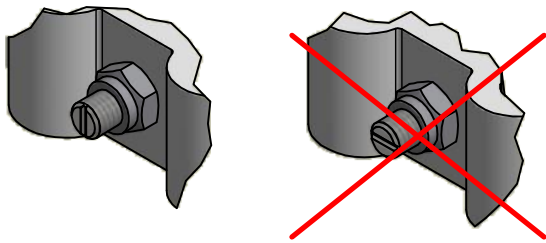

Mounting Side+ profile

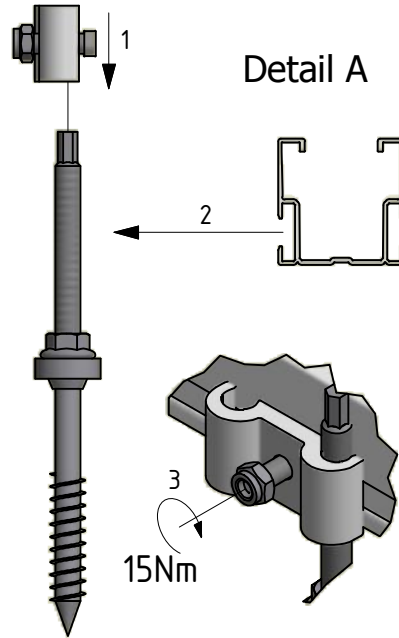

Detail A

Detail B

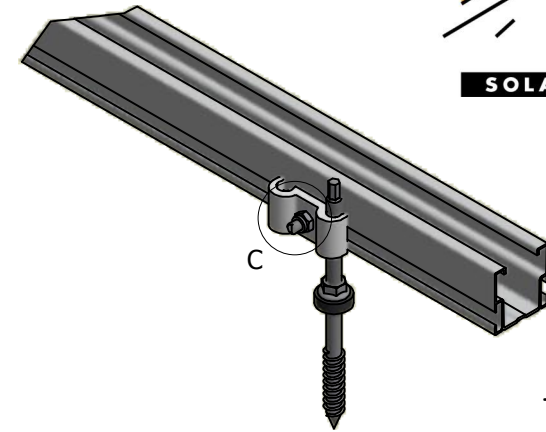

Top view

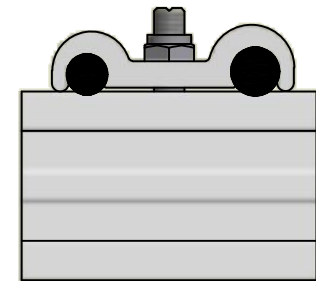

When the bolt is tightened, the hangerbolt is forced into the aluminium profile.

At least 1 mm thread above the clamp.

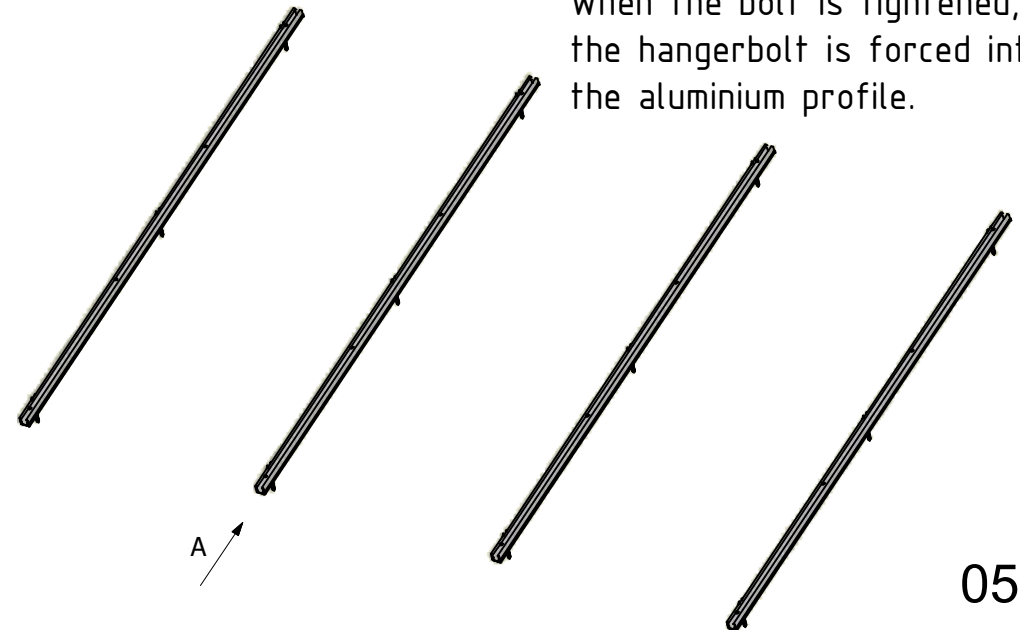
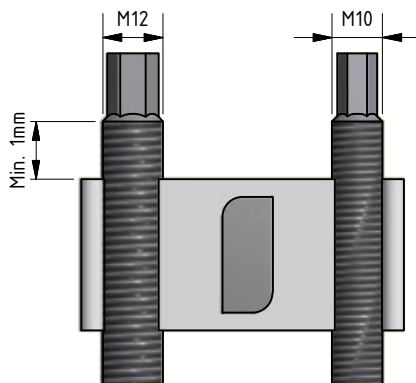

# Mounting the Side+ coupling

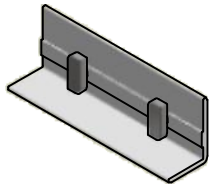

72.48.65

Detail A

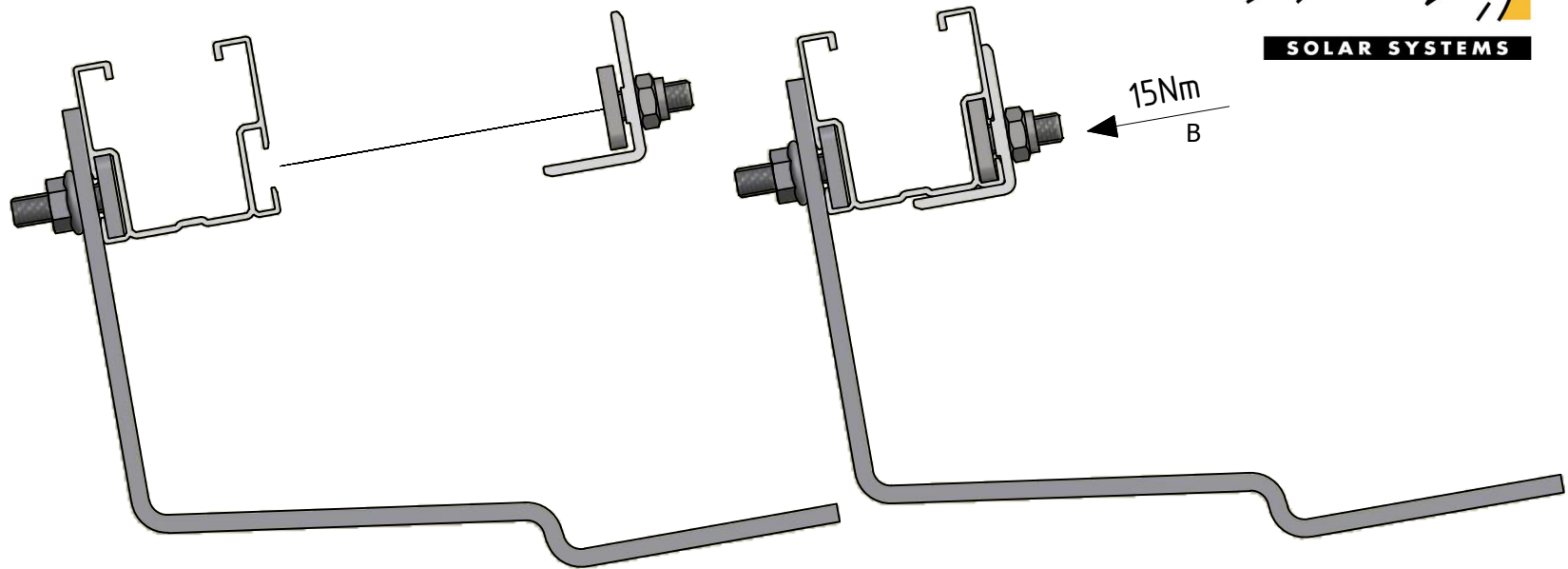

The groove of the bolt corresponds with the orientation of the bolt head.

Detail B

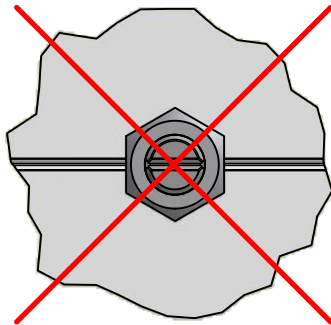
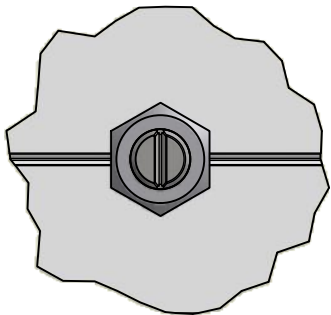

Optional:



73.90.50

Optional:

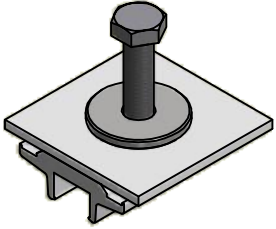

77.42.23

Optional:



73.30.20

### Mounting optional products

**VAN DER VALK**



**SOLAR SYSTEMS**

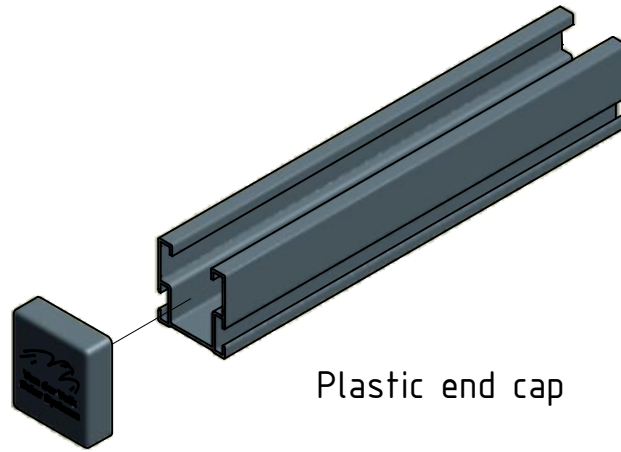

Plastic end cap

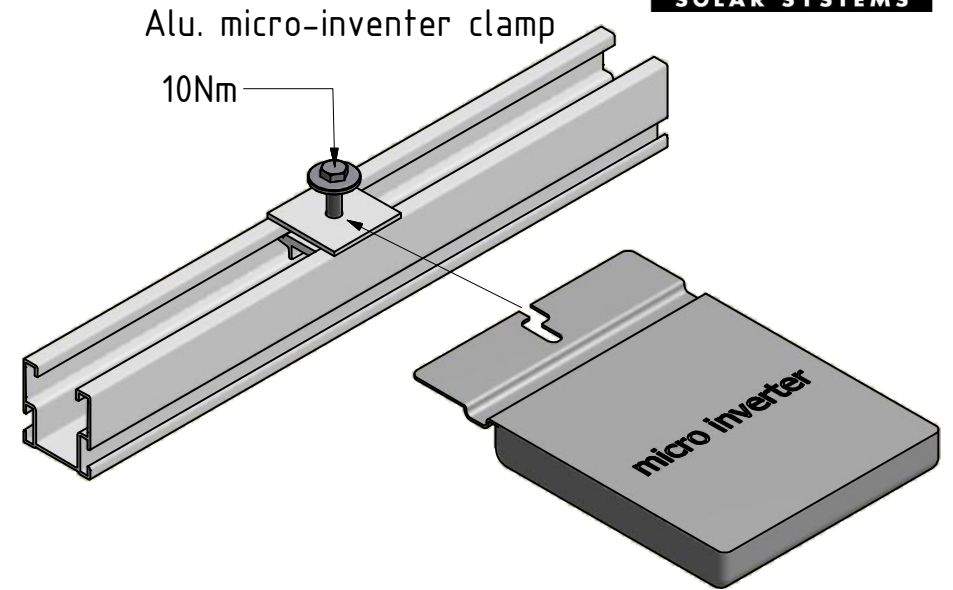

Alu. micro-inverter clamp

10Nm

micro inverter

Plastic panel alignment pins

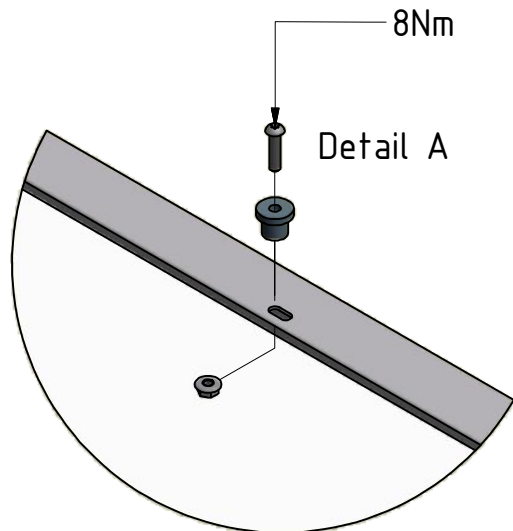

8Nm

Detail A

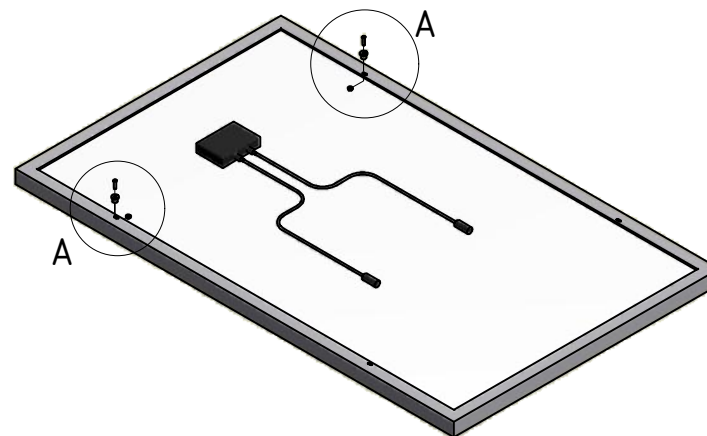

A

A

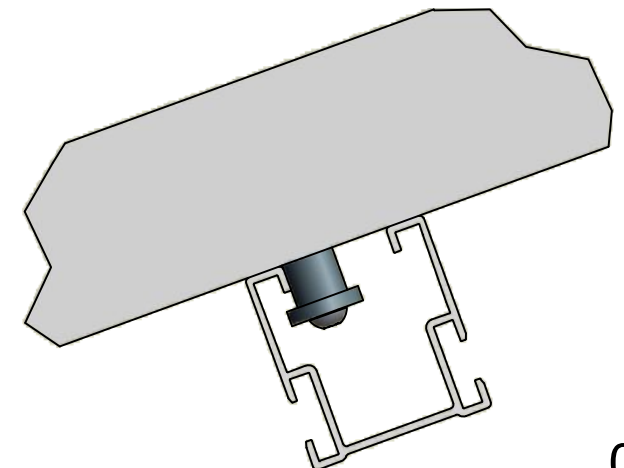

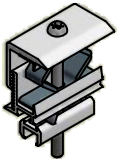

72.15.52

## Mounting panels

**VAN DER VALK**



**SOLAR SYSTEMS**

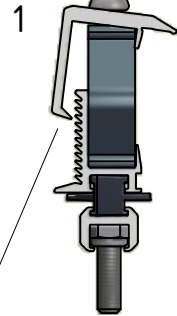

Take the End Clamp out of it's slot to make the assembly easier.

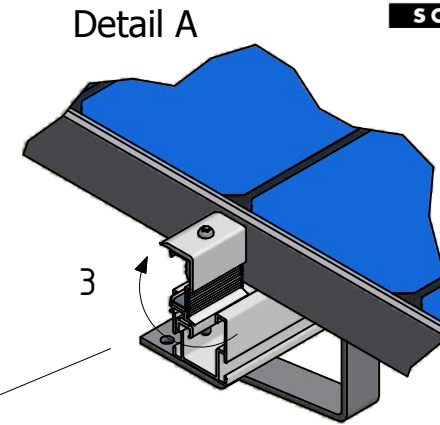
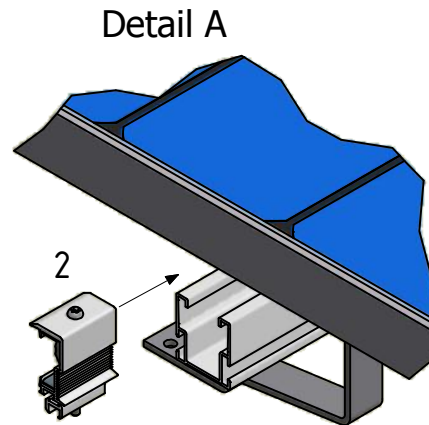

The End Clamp can only be turned clockwise, so make sure that the End Clamp is placed the right way.

Put the End Clamp in the right slot to continue the assembly.

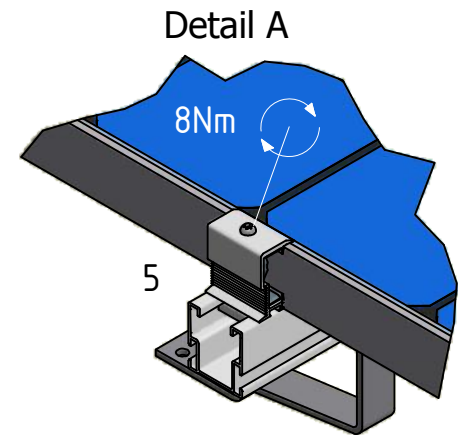
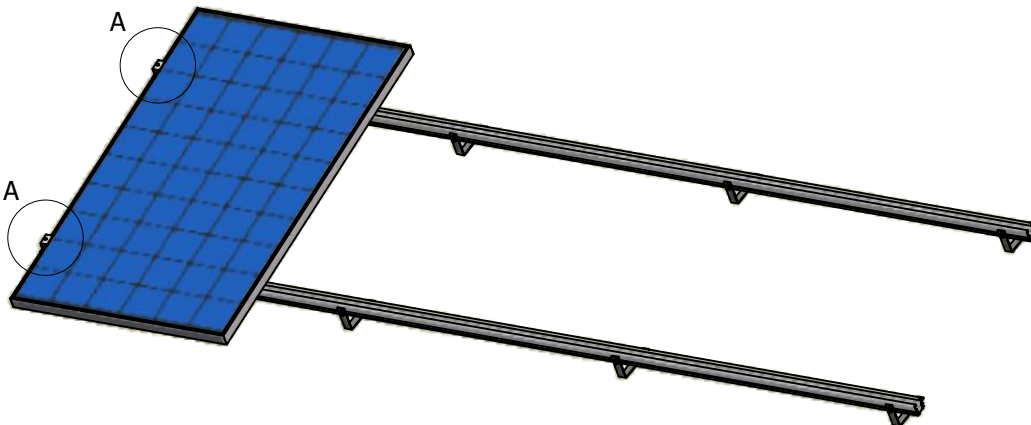



72.15.50

### Mounting panels

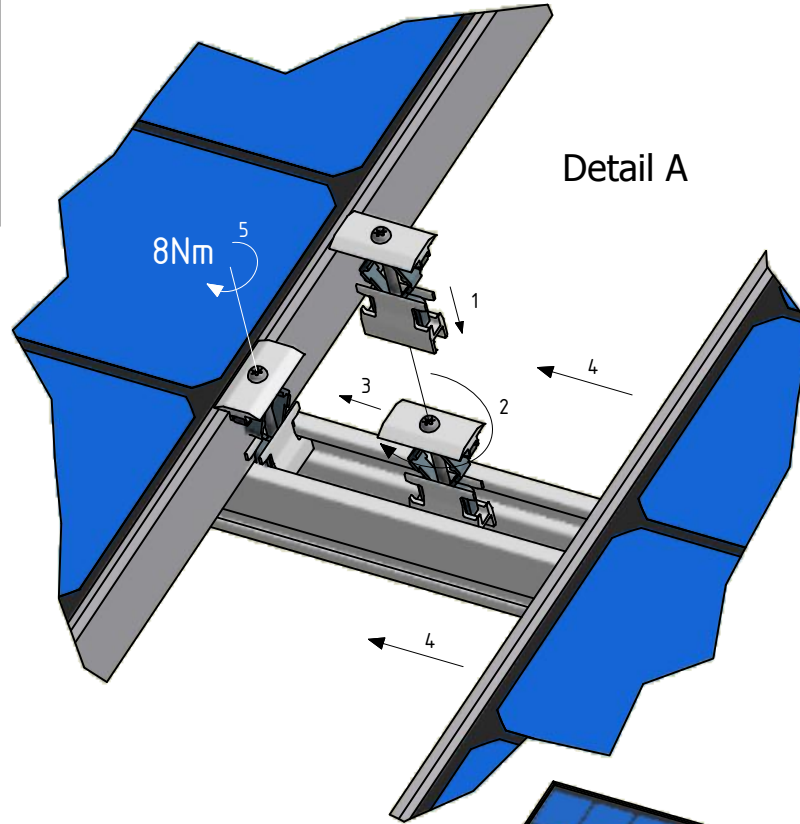

Detail A

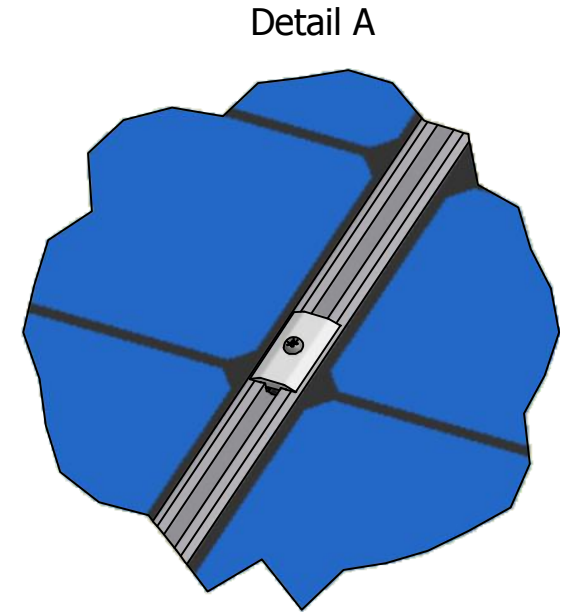

Detail A

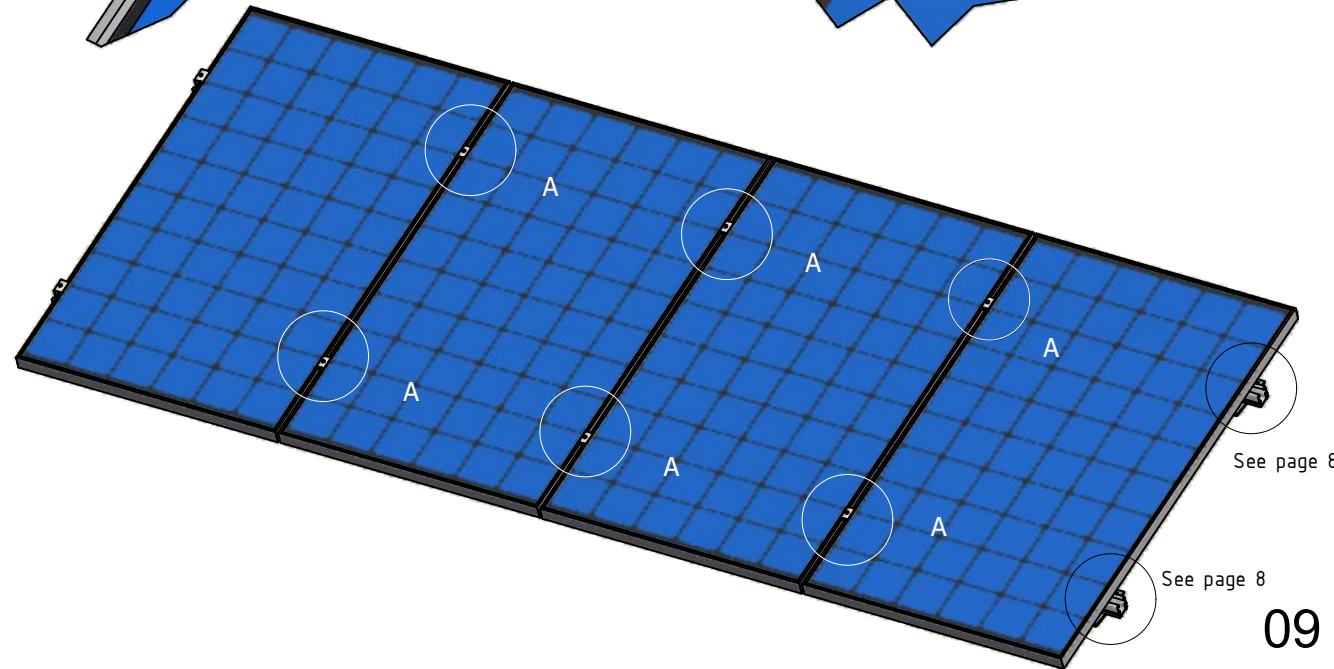

See page 8

See page 8



optional:



73.20.01  
Max. cable  
diameter Ø9 mm

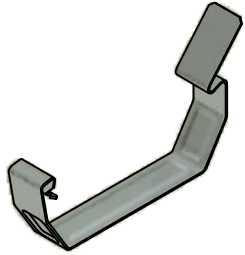

73.20.05  
Max. cable  
diameter Ø9 mm

### Mounting cable clamps

Mounting cable clamp on panel.

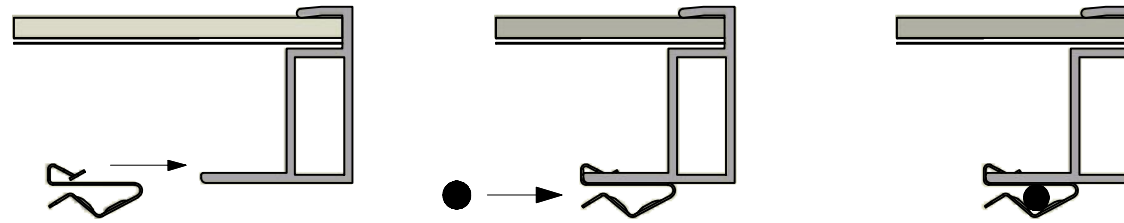

Mounting cable clamp on Side+ profile.

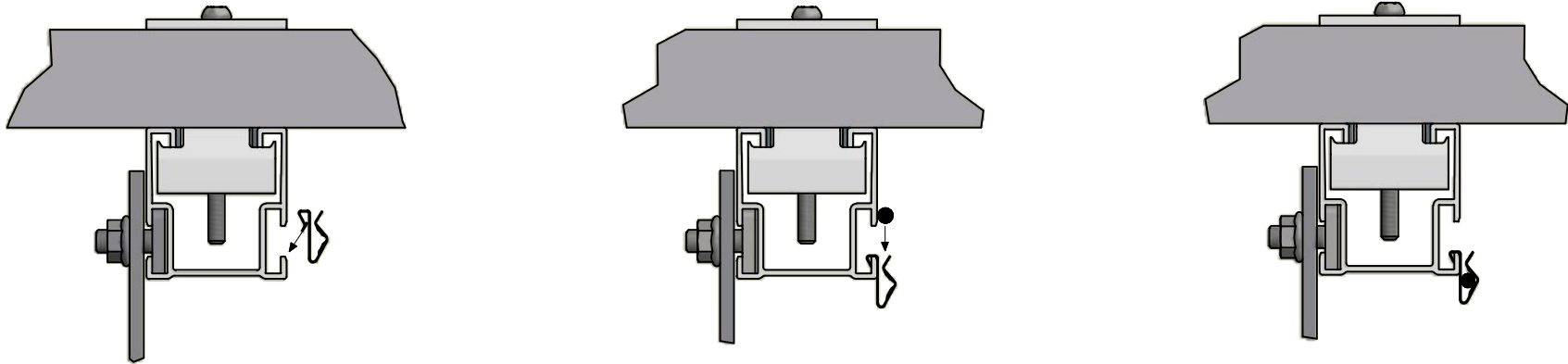

Mounting cable clamp on Side+ profile.

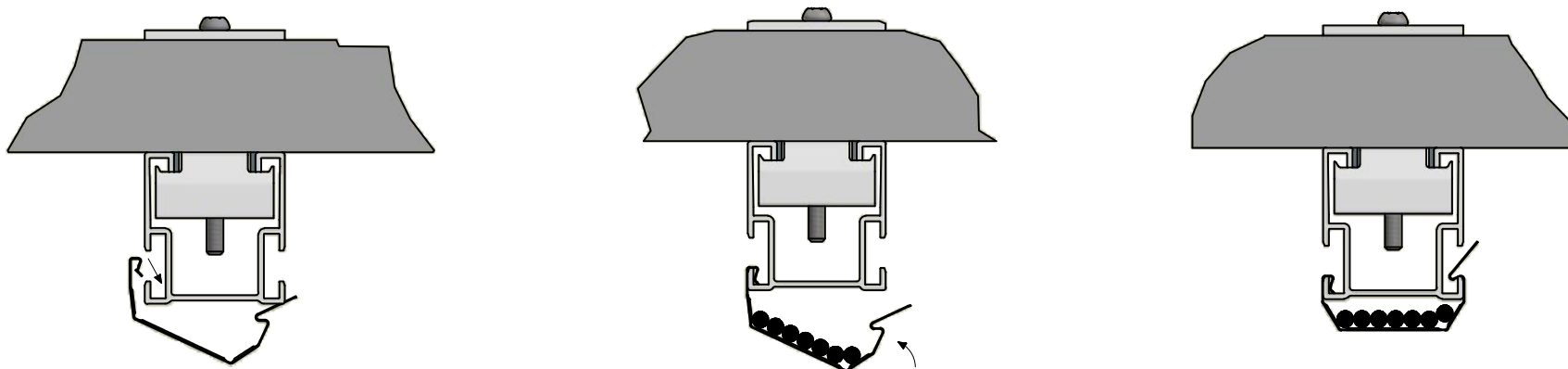



## Van der Valk Solar Systems

Van der Valk Solar Systems is a specialist company that is fully focused on developing and producing mounting systems for use with solar panels. To this end we work in close collaboration with Van der Valk Systemen, our sister company.

Van der Valk Systemen has been a well-known name in the field of moving systems and stationary components for the greenhouse horticultural sector and industry throughout the world since 1963. Van der Valk Systemen's high quality products have been individually developed from a scientific approach and produced with mathematical precision. They are made to be low-maintenance and to stand out thanks to their durability, reliability, functionality and ease of assembly.

Both Van der Valk Systemen and Van der Valk Solar Systems only introduce innovative products to the market. Our shared business complex consists of 20,000 m<sup>2</sup> of offices and production facilities, in which modern machinery and the latest technologies facilitate development, manufacturing and testing that is fast, flexible and precise.



### Developer and producer of solar mounting systems for:



Open Fields   Pitched Roofs   Flat Roofs   Greenhouses   Water Features

PLEASE CONTACT VAN DER VALK SOLAR SYSTEMS, YOUR INSTALLATION COMPANY  
OR PROJECT ORGANISATION FOR FULL INFORMATION.